



BMW K 1200 R (2005)

Slip-On Exhaust System

# Akrapovic Slip-On Exhaust System

## for the BMW K 1200 R (2005)

The muscular K 1200 R in all its glory. As the naked version of the sporty S model it also displays sporty elegance and top-notch design. We have developed an Akrapovic SLIP-ON exhaust system for riders who want to make a slight alteration to the bike's looks and performance with a minimum modification. The system fits beautifully with the strong character of the BMW. It has been developed in an open version and is not approved for street use.

### PERFORMANCE

Measurements of the Akrapovic SLIP-ON system on the BMW K 1200 R (without noise damper):

Power & Torque: the system shows its effects on engine performance mainly at the top of the rpm range, which can be seen clearly from the power and torque curves. At 10100 rpm we measured over 150 HP, with the max. increased power of 7.4 HP coming in at 7600 rpm, which is also the point where the max. increased torque is delivered.

### CONFIGURATION

The Akrapovic SLIP-ON system is composed of a cylindrical stainless steel link pipe attached to the muffler with a sleeve joint held together with silicon-shielded tensioning springs. At the other end the Akrapovic link pipe is attached to the stock header assembly with another sleeve joint, this time held together with the stock metal clamp. The muffler is available with either a titanium or carbon-fiber outer sleeve. The difference is purely visual, as the performance for both models is the same. The muffler interior (inlet and outlet cap, inner perforation) is made entirely of titanium, making it much lighter than the stock muffler, and the muffler is attached to the frame using an Akrapovic carbon-fiber clamp.

	PERFORMANCE		
	stock	AKRAPOVIC	max. increased power
max. rear wheel power HP / rpm (measured on Dynojet ATV)	145.7 / 9900	150.4 / 10100	7.4 / 7600

	CONFIGURATION		
	header tubes	collector	link pipe
material	-	-	STAINLESS STEEL
tube shape	-	-	CYLINDRICAL

interference crossover tubes	-	lambda sensor	-	
header tube inner sleeves	-	header tube flanges	-	
header tubes - collector connection	-	collector / header tube - link pipe connection	SLEEVE JOINT + STOCK METAL CLAMP	
link pipe - muffler connection	SLEEVE JOINT + SILICON SHIELDED SPRINGS	muffler inlet cap /outlet cap	TITANIUM / TITANIUM	
muffler metal interior	TITANIUM	muffler outer sleeve	TITANIUM / CARBON-FIBER	
muffler clamp	CARBON-FIBER	muffler bracket	-	
muffler insert	EU	-	heat shield	-
	US	-	catalytic converter	-

	ADDITIONAL DATA				
	stock	AKRAPOVIC		difference	
weight comparison (kg)	7.60	S.S. linkpipe	TITANIUM link pipe	stock - S.S.	stock - TITANIUM
		2.20	-	5.40	-
noise measurements (dB / rpm)	stock		AKRAPOVIC		
	95.4 / 5125		100.5 / 5125 (open)		
possibility of periodic service without removing A.E.S.	oil		oil filter		
	YES		YES		
legal for street use	NO				

Technical specifications of Akrapovic exhaust systems and related products subject to change without notice.

Product code: 104428 (S-B12SO1-C)  
104427 (S-B12SO1-T)

# Akrapovic Slip-On Exhaust System for the BMW K 1200 R (2005)



CARBON-FIBER  
MUFFLER CLAMP

Road  
Program

Product code: 104428 (S-B12SO1-C)  
104427 (S-B12SO1-T)

# Akrapovic Slip-On Exhaust System for the BMW K 1200 R (2005)



Akrapovic Exhaust System Technology copyright 2005, all rights reserved

Road  
Program

Product code: 104428 (S-B12S01-C)  
104427 (S-B12S01-T)

# Akrapovic Slip-On Exhaust System for the BMW K 1200 R (2005)



Akrapovic Exhaust System Technology copyright 2005, all rights reserved

Road Program

Product code: 104428 (S-B12SO1-C)  
104427 (S-B12SO1-T)

# Akrapovic Slip-On Exhaust System for the BMW K 1200 R (2005)

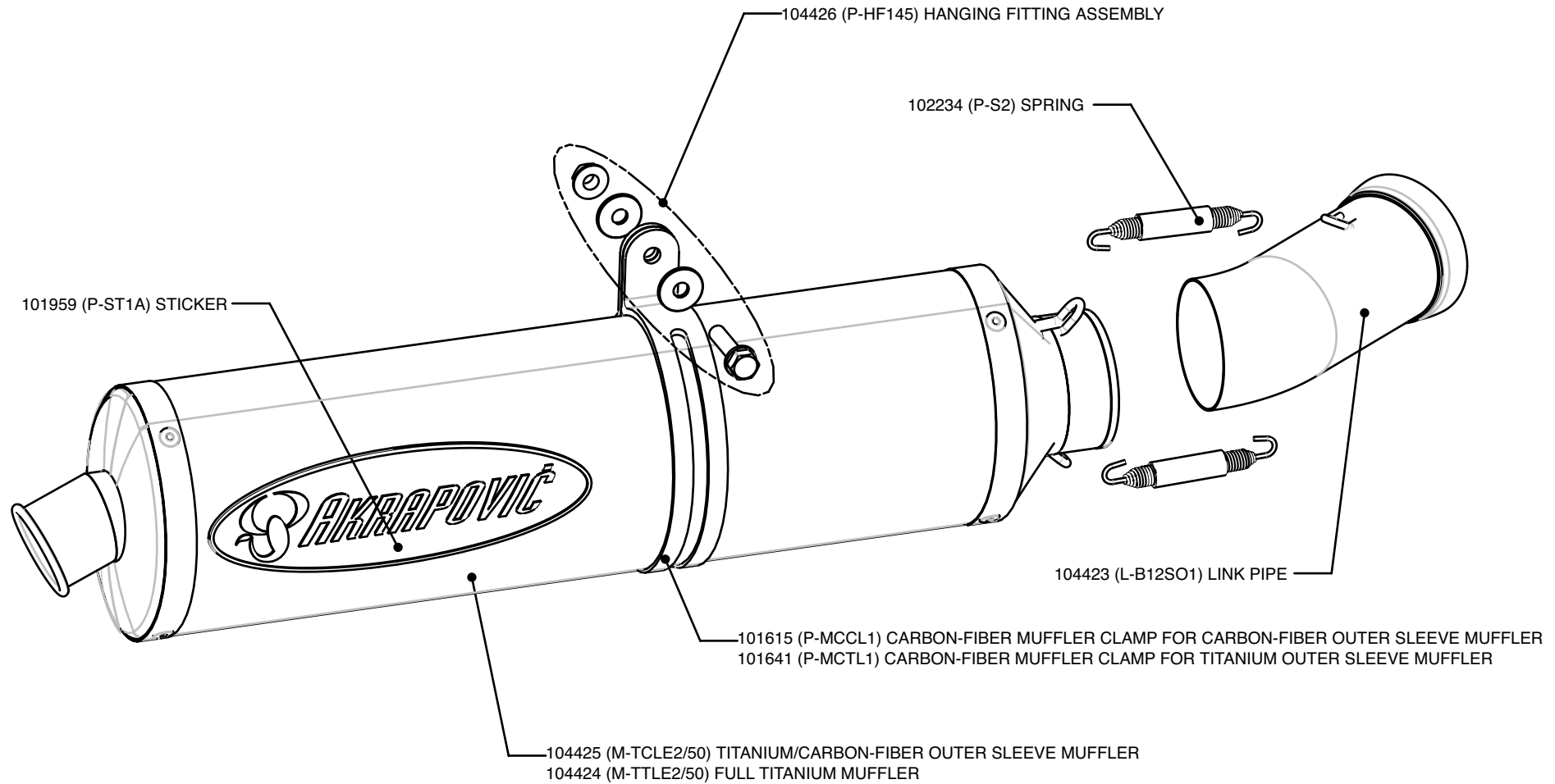

Road  
Program

Product code: 104428 (S-B12SO1-C)  
104427 (S-B12SO1-T)

# Akrapovic Slip-On Exhaust System for the BMW K 1200 R (2005)

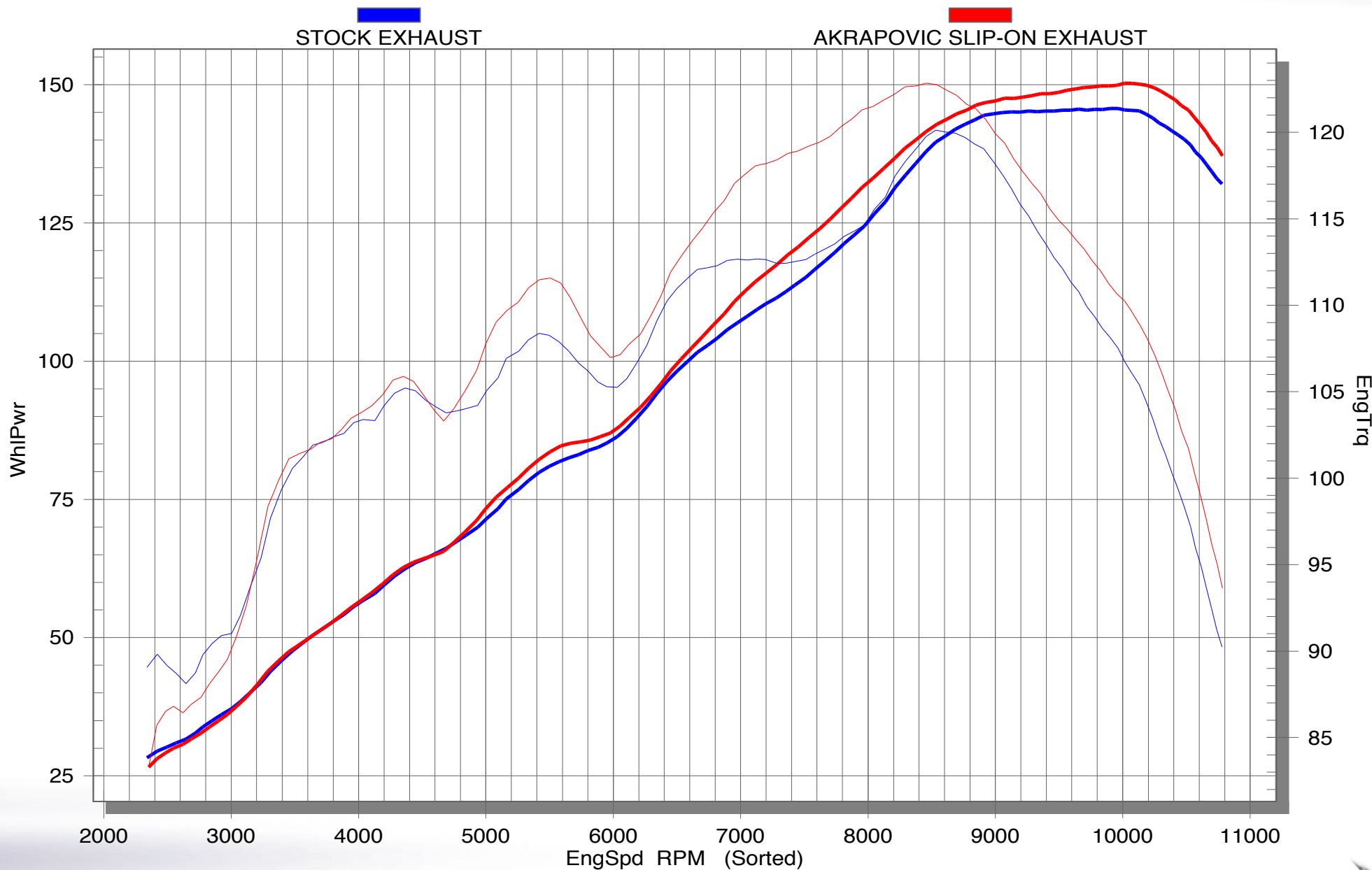

Road Program

Product code: 104428 (S-B12SO1-C)  
104427 (S-B12SO1-T)