



Honda CFR 250R (06 - 07)

Evolution Exhaust System

Akrapovic Racing & Evolution Exhaust System

for the Honda CRF250R (2006 - 2007)

Akrapovic RACING and EVOLUTION system are designed for riders who know who to take full advantage of the specific performance benefits offered by these systems. This generally refers to professionally oriented riders. We should especially mention the new Akrapovic HEXAGONAL mufflers, which with their carbon-fiber outlet caps match the design of the Honda exceptionally well.

PERFORMANCE

Measurements of the Akrapovic EVOLUTION system on the HONDA CRF 250R:

Power & Torque: the performance advantages of the Akrapovic Evolution system on the Honda CRF 250R can be found mainly in the upper and top end of the rpm range. At the top end the power curve the range of the peak power is extended, as well as increased with respect to the stock power output.

CONFIGURATION

The twin-pipe Akrapovic Evolution system uses titanium tubing and the twin-pipe Akrapovic Racing uses stainless steel tubing. The tubes for the header assembly are flared to provide improved exhaust gas flow. The systems' individual components - header tubes, collectors and link pipes - are attached using sleeve joints held together with silicon-shielded springs. The link pipes, which are welded to the mufflers, are extremely short. This system includes the HEXAGONAL mufflers, which go exceptionally well with the design of the Honda. The mufflers have in case of Evolution titanium inlet caps and perforated inner sleeves, in case of Racing stainless steel inlet caps and perforated inner sleeves. The outlet caps are made of carbon-fiber. The outer sleeves are made of titanium for the Racing version. For the Evolution both options of the outer sleeve are available - carbon-fiber and titanium. The mufflers are attached to the frame using Akrapovic offroad carbon-fiber clamps. Evolution system also includes a carbon-fiber heat shield.

	PERFORMANCE		
	stock	AKRAPOVIC	max. increased power
max. rear wheel power HP / rpm <small>(measured on Dynojet ATV)</small>	34.5 / 10900	35.5 / 11500	2.1 / 12000

	CONFIGURATION		
	header tubes	collector	link pipe
material	TITANIUM (Evolution) STAINLESS STEEL (Racing)	-	TITANIUM (Evolution) STAINLESS STEEL (Racing)
tube shape	FLARED	-	FLARED

interference crossover tubes	-	lambda sensor	-
header tube inner sleeves	S.S. CNC MACHINED	header tube flanges	S.S. LASER CUT
header tubes - collector connection	-	collector / header tube - link pipe connection	SLEEVE JOINT + SILICON SHILDED SPRING
link pipe - muffler connection	SLEEVE JOINT + SILICON SHILDED SPRING	muffler inlet cap / outlet cap	TITANIUM (Evolution), STAINLESS STEEL (Racing) / CARBON-FIBER
muffler metal interior	TITANIUM (Evolution) STAINLESS STEEL (Racing)	muffler outer sleeve	TITANIUM or CARBON-FIBER (Evolution) TITANIUM (Racing)
muffler clamp	CARBON-FIBER ROAD	muffler bracket	-
muffler insert	EU	-	heat shield
	US	-	carbon fiber
		catalytic converter	-

	ADDITIONAL DATA				
	stock	AKRAPOVIC		difference	
		RACING	EVOLUTION	stock - RACING	stock - EVOLUTION
weight comparison (kg)	4.13	2.91	2.49	1.22	1.64
noise measurements (dB / rpm)	stock		AKRAPOVIC		
	96 / 5000		96 / 5000		
possibility of periodic service without removing A.E.S.	oil		oil filter		
	YES		YES		
legal for street use	NO				

Technical specifications of Akrapovic exhaust systems and related products subject to change without notice.

Off-Road Program

Product code: 106650 (S-H2MR5-VT) ,106646 (S-H2MET5T-VT)

Akrapovic Racing & Evolution Exhaust System for the Honda CRF250R (2006 - 2007)



HEXAGONAL
SHAPED MUFFLER



CARBON-FIBER
MUFFLER CLAMPS



Akrapovic Exhaust System Technology copyright 2005, all rights reserved

Off-Road
Program

Product code: 106650 (S-H2MR5-VT) ,106646 (S-H2MET5T-VT)

Akrapovic Racing & Evolution Exhaust System for the Honda CRF250R (2006 - 2007)



Akrapovic Exhaust System Technology copyright 2005, all rights reserved

Off-Road
Program

Product code: 106650 (S-H2MR5-VT) ,106646 (S-H2MET5T-VT)

Akrapovic Racing & Evolution Exhaust System

for the Honda CRF250R (2006 - 2007)



Off-Road Program

Product code: 106650 (S-H2MR5-VT) ,106646 (S-H2MET5T-VT)

Akrapovic Racing & Evolution Exhaust System

for the Honda CRF250R (2006 - 2007)

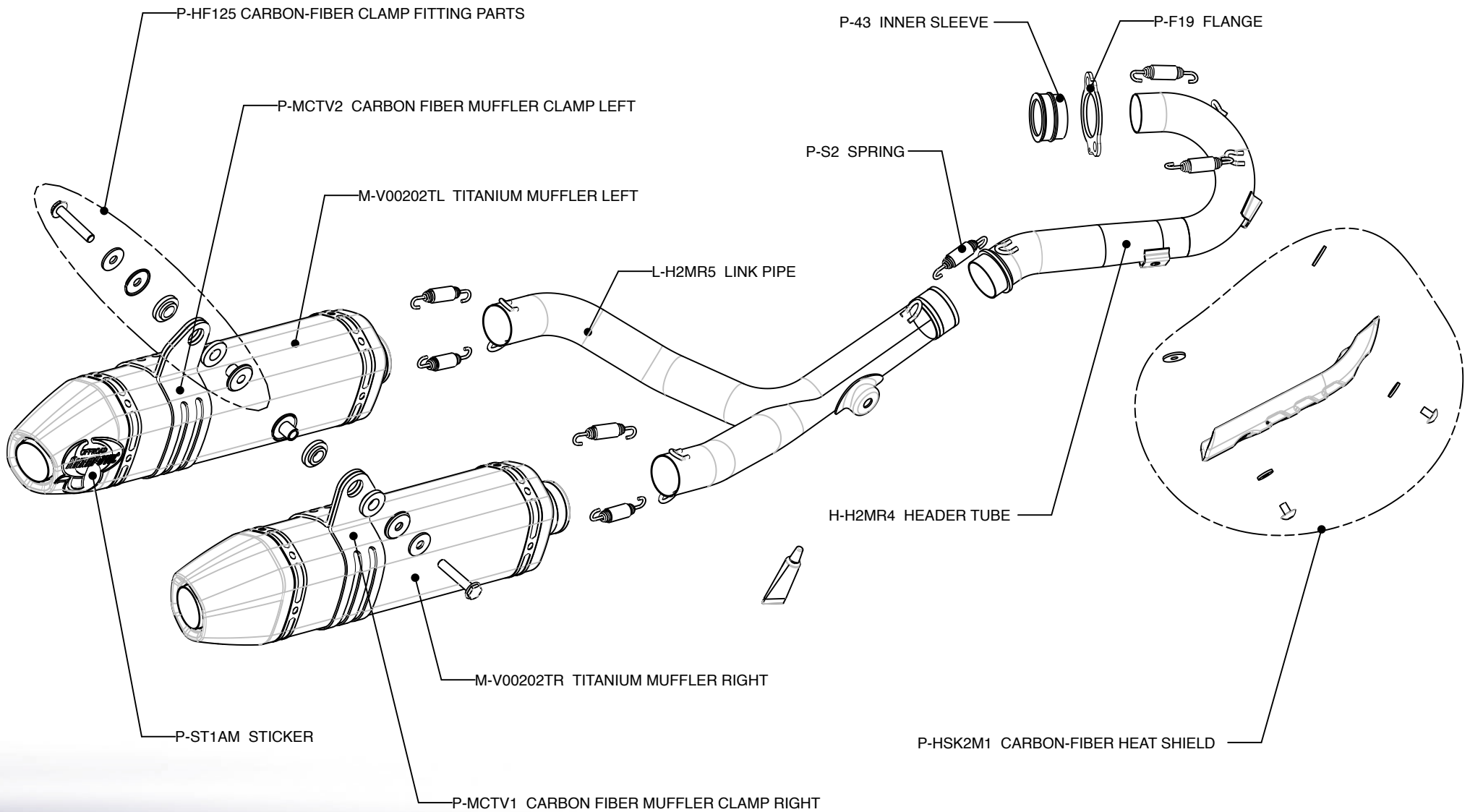

Off-Road Program

Product code: 106650 (S-H2MR5-VT) ,106646 (S-H2MET5T-VT)

Akrapovic Racing & Evolution Exhaust System

for the Honda CRF250R (2006 - 2007)

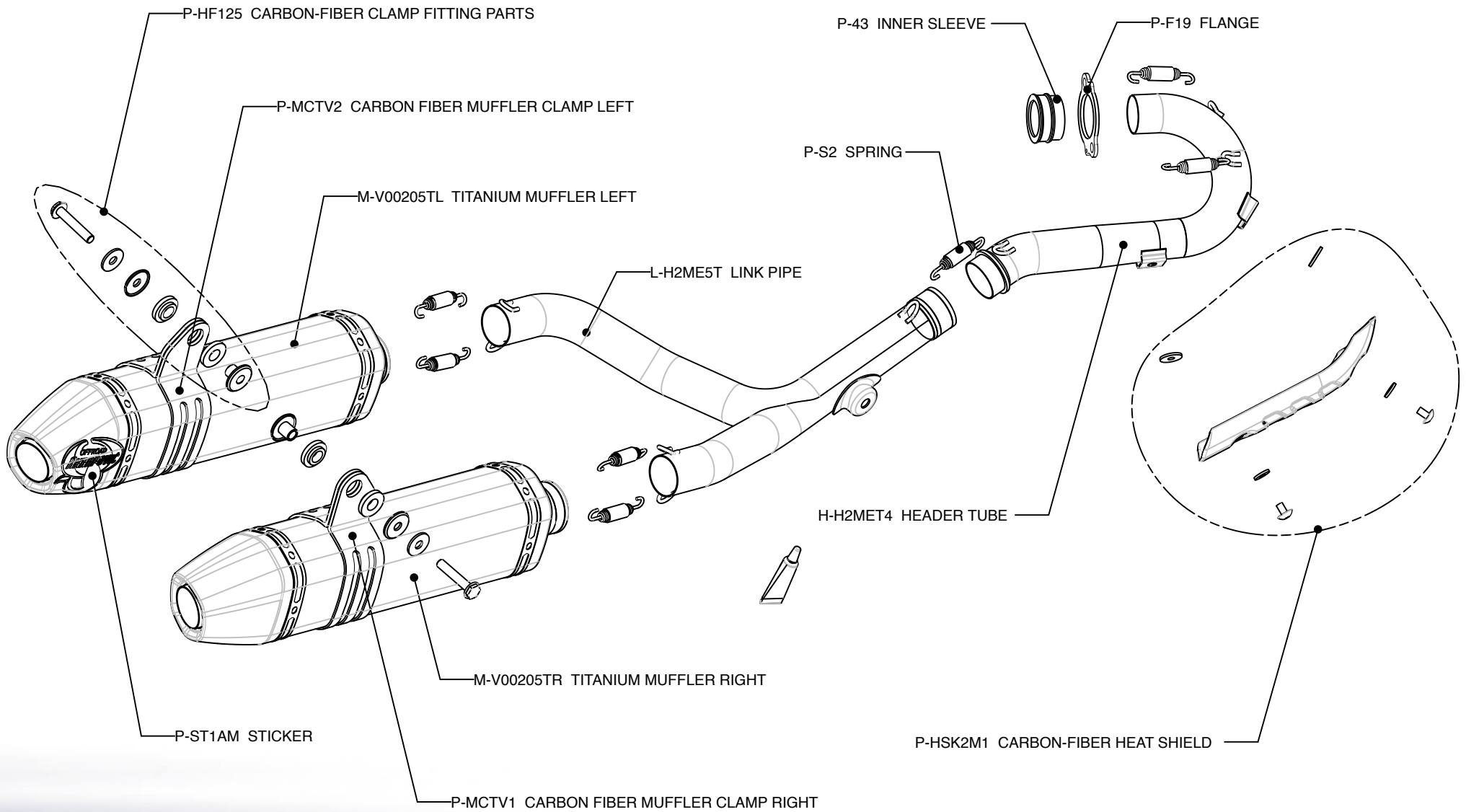

Off-Road Program

Product code: 106650 (S-H2MR5-VT) ,106646 (S-H2MET5T-VT)

Akrapovic Racing & Evolution Exhaust System

for the Honda CRF250R (2006 - 2007)

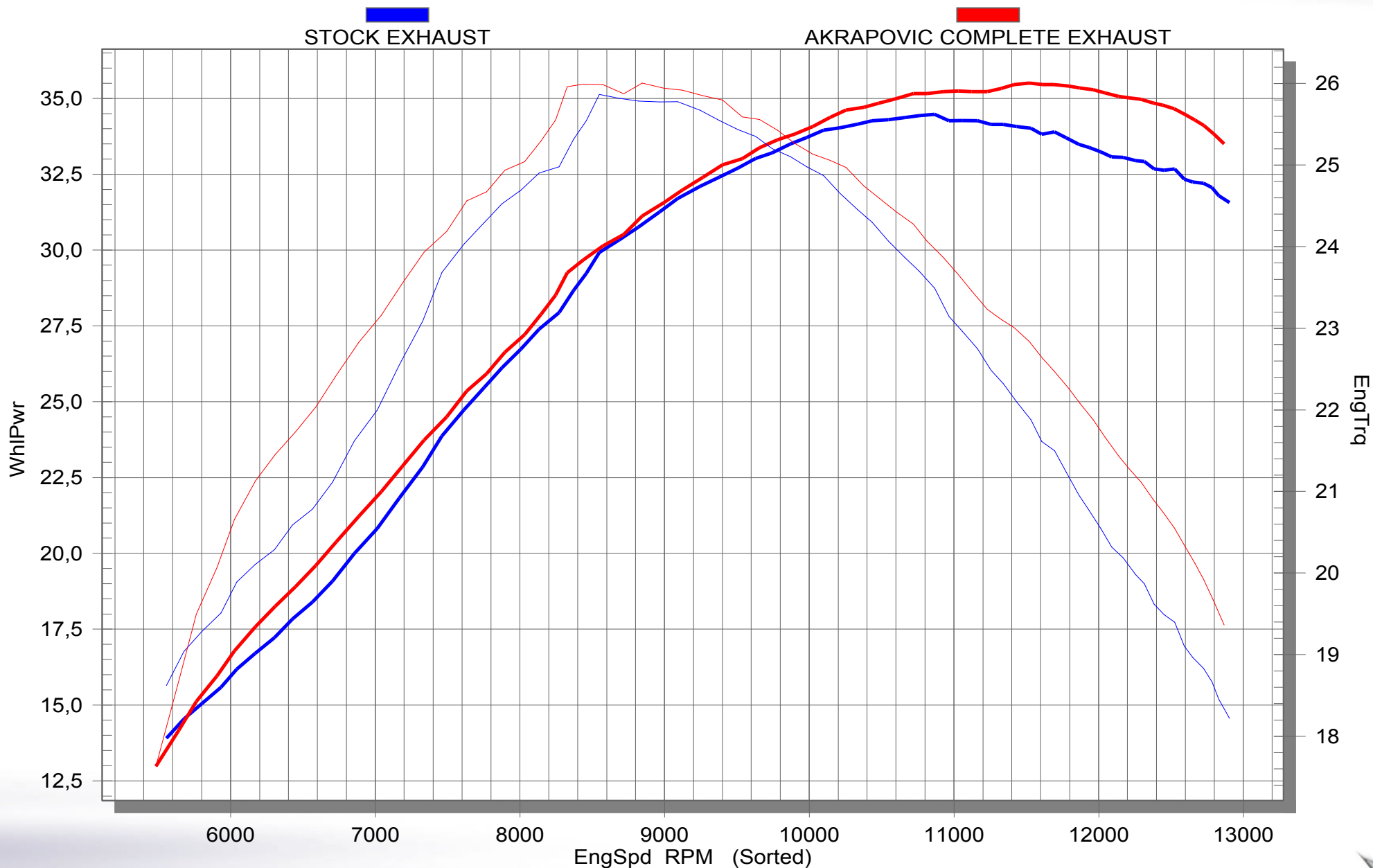

Off-Road Program

Product code: 106650 (S-H2MR5-VT) ,106646 (S-H2MET5T-VT)

