



Honda CRF 250R (06 - 07)

Racing & Evolution Exhaust System

Akrapovic Racing & Evolution Exhaust System (single muffler)

for the Honda CRF 250R (2006 - 2007)

Like the Akrapovic dual muffler RACING and EVOLUTION versions, the single muffler RACING and EVOLUTION system is designed for riders who know who to take full advantage of the specific performance benefits offered by these systems. We should especially mention the new Akrapovic HEXAGONAL design muffler, which with its carbon-fiber outlet cap goes exceptionally well with the design of the Honda.

The muffler has a noise damper for the EU and other non-American markets, and a mandatory spark arrester for the American market.

PERFORMANCE

Measurements of the Akrapovic EVOLUTION system on the HONDA CRF 250R (without muffler insert):

Power & Torque: the single muffler version delivers a performance increase mainly in the middle of the rpm range and at the top end and overrev. Good riders will know how to make the most of the advantage.

CONFIGURATION

The Akrapovic Evolution system uses titanium tubing and the Akrapovic Racing uses stainless steel tubing. The tubes for the header assembly are flared to provide improved exhaust gas flow, while the link pipe is conical. The systems' individual components – header tube and link pipe \varnothing are attached using a sleeve joint held together with a silicon-shielded spring. The link pipe is welded to the muffler.

This system, unlike the stock system, has just a single muffler. It features a HEXAGONAL design muffler, which goes exceptionally well with the design of the Honda. The muffler have in case of Evolution titanium inlet cap and perforated inner sleeve, in case of Racing stainless steel inlet cap and perforated inner sleeve. The outlet cap is made of carbon-fiber. The outer sleeve is made of titanium for the Racing version. For the Evolution both options of the outer sleeve are available – carbon-fiber and titanium. The muffler is attached to the frame using an Akrapovic offroad carbon-fiber clamp. Evolution system also includes a carbon-fiber heat shield.

The muffler has a noise damper for the EU and other non-American markets, and a mandatory spark arrester for the American market.

	PERFORMANCE		
	stock	AKRAPOVIC	max. increased power
max. rear wheel power HP / rpm (measured on Dynojet ATV)	34.5 / 10900	35.6 / 11500	2 / 11800

	CONFIGURATION		
	header tubes	collector	link pipe
material	TITANIUM (Evolution) STAINLESS STEEL (Racing)	-	TITANIUM (Evolution) STAINLESS STEEL (Racing)
tube shape	FLARED	-	CONICAL

interference crossover tubes	-	lambda sensor	-	
header tube inner sleeves	S.S. CNC MACHINED	header tube flanges	S.S. LASER CUT	
header tubes - collector connection	-	collector / header tube - link pipe connection	SLEEVE JOINT + SILICON SHILDED SPRING	
link pipe - muffler connection	WELDED	muffler inlet cap / outlet cap	TITANIUM / CARBON-FIBER	
muffler metal interior	TITANIUM (Evolution) STAINLESS STEEL (Racing)	muffler outer sleeve	TITANIUM or CARBON-FIBER (Evolution) TITANIUM (Racing)	
muffler clamp	CARBON-FIBER OFF ROAD	muffler bracket	-	
muffler insert	EU	NOISE DAMPER	heat shield	CARBON FIBER
	US	SPARK ARRESTER	catalytic converter	-

	ADDITIONAL DATA				
	stock	AKRAPOVIC		difference	
weight comparison (kg)	4.13	RACING	EVOLUTION	stock - RACING	stock - EVOLUTION
		2.35	1.95	1.78	2.22
noise measurements (dB / rpm)	stock		AKRAPOVIC		
	96 / 5000		96 / 5000		
possibility of periodic service without removing A.E.S.	oil		oil filter		
	YES		YES		
legal for street use	NO				

Technical specifications of Akrapovic exhaust systems and related products subject to change without notice.

Product code: 106667 (S-H2MR4-QT) EU market, 106668 (S-H2MR4-QTA) US market
105174 (S-H2MET4-QT) EU market, 105151 (S-H2MET4-QTA) US market

Akrapovic Racing & Evolution Exhaust System (single muffler)

for the Honda CRF 250R (2006 - 2007)



HEXAGONAL SHAPED MUFFLER



CARBON-FIBER MUFFLER CLAMP

Product code: 106667 (S-H2MR4-QT) EU market, 106668 (S-H2MR4-QTA) US market
105174 (S-H2MET4-QT) EU market, 105151 (S-H2MET4-QTA) US market

Akrapovic Racing & Evolution Exhaust System (single muffler)

for the Honda CRF 250R (2006 - 2007)



Akrapovic Exhaust System Technology copyright 2006, all rights reserved

Off-Road Program

Product code: 106667 (S-H2MR4-QT) EU market, 106668 (S-H2MR4-QTA) US market
105174 (S-H2MET4-QT) EU market, 105151 (S-H2MET4-QTA) US market

Akrapovic Racing & Evolution Exhaust System (single muffler)

for the Honda CRF 250R (2006 - 2007)



Off-Road Program

Product code: 106667 (S-H2MR4-QT) EU market, 106668 (S-H2MR4-QTA) US market
105174 (S-H2MET4-QT) EU market, 105151 (S-H2MET4-QTA) US market

Akrapovic Racing Exhaust System (single muffler)

for the Honda CRF 250R (2006 - 2007)

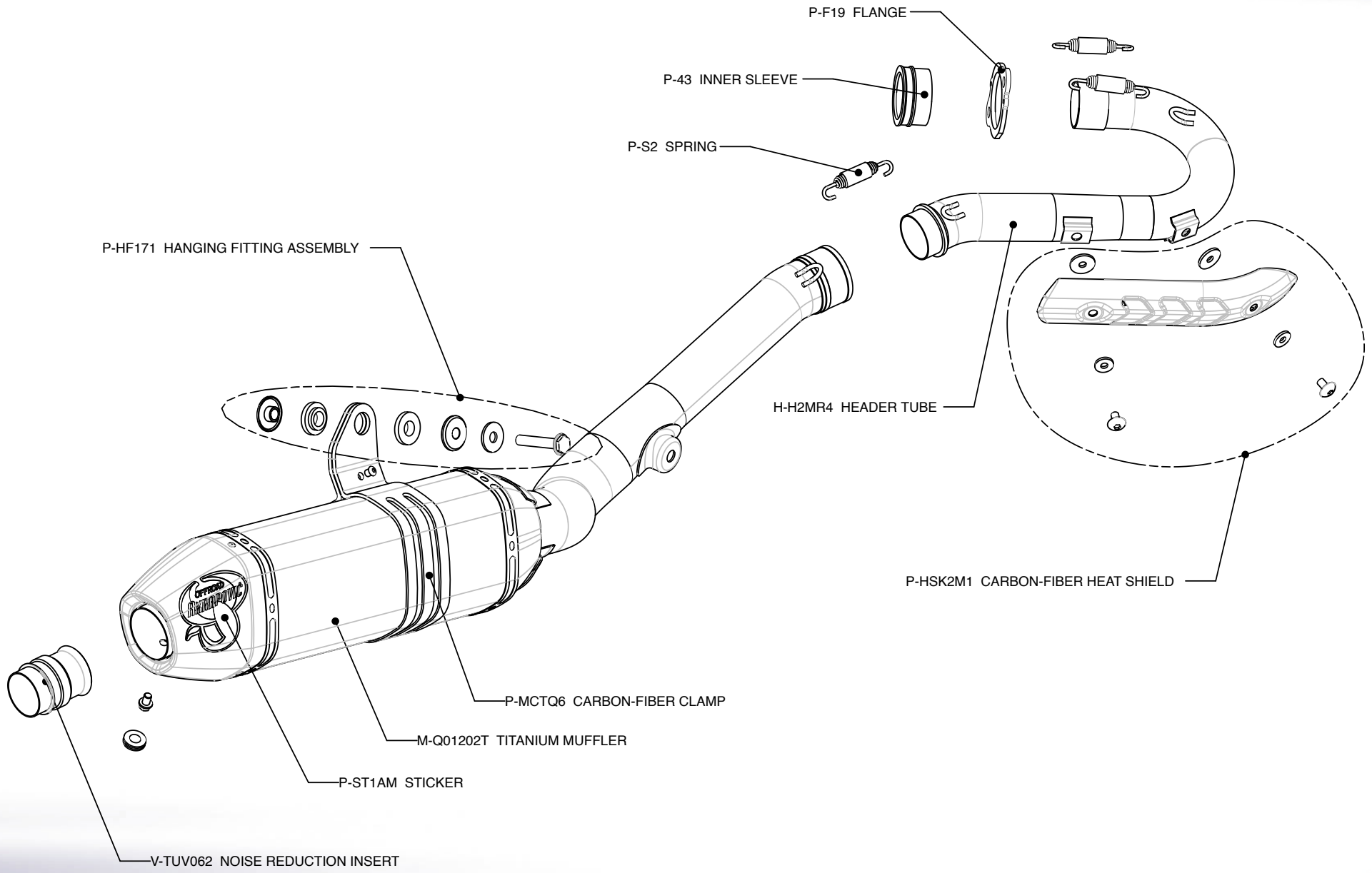

Akrapovic Exhaust System Technology copyright 2006, all rights reserved

Off-Road Program

Product code: 106667 (S-H2MR4-QT) EU market



Akrapovic Racing Exhaust System (single muffler)

for the Honda CRF 250R (2006 - 2007)

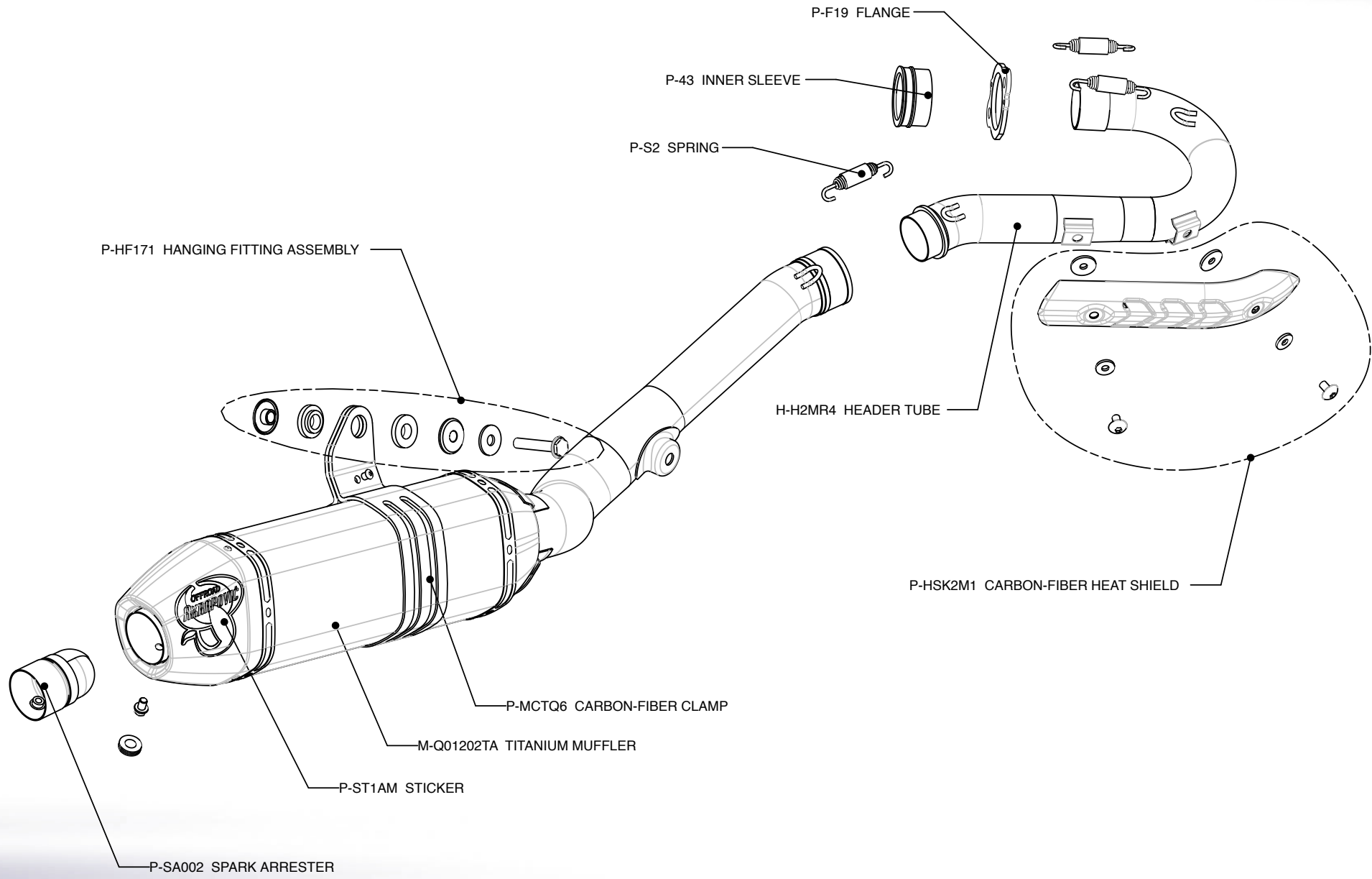

Off-Road Program

Product code: 106668 (S-H2MR4-QTA) US market



Akrapovic Exhaust System Technology copyright 2006, all rights reserved

Akrapovic Evolution Exhaust System (single muffler)

for the Honda CRF 250R (2006 - 2007)

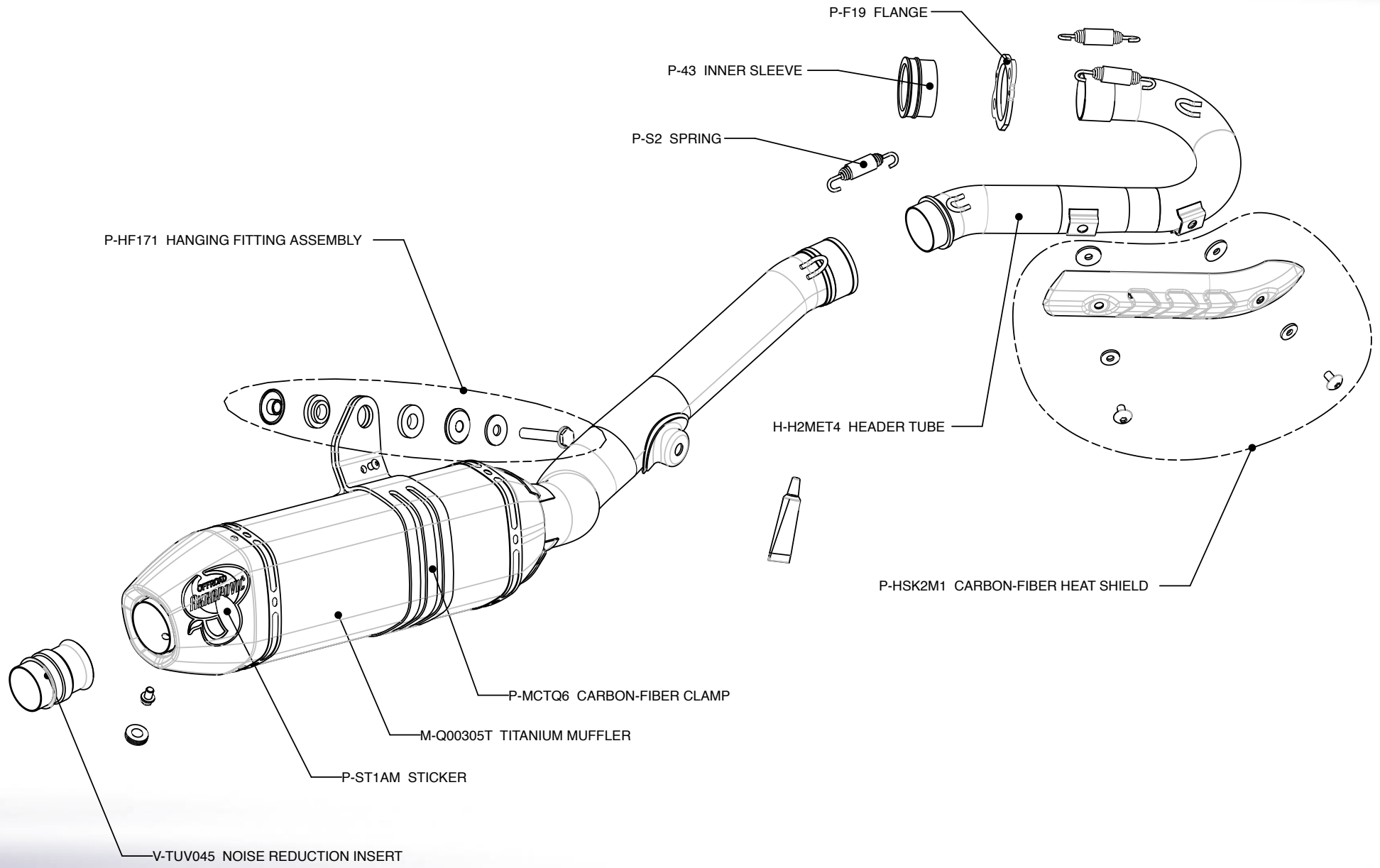

Off-Road Program

Product code: 105174 (S-H2MET4-QT) EU market



Akrapovic Exhaust System Technology copyright 2006, all rights reserved

Akrapovic Evolution Exhaust System (single muffler)

for the Honda CRF 250R (2006 - 2007)

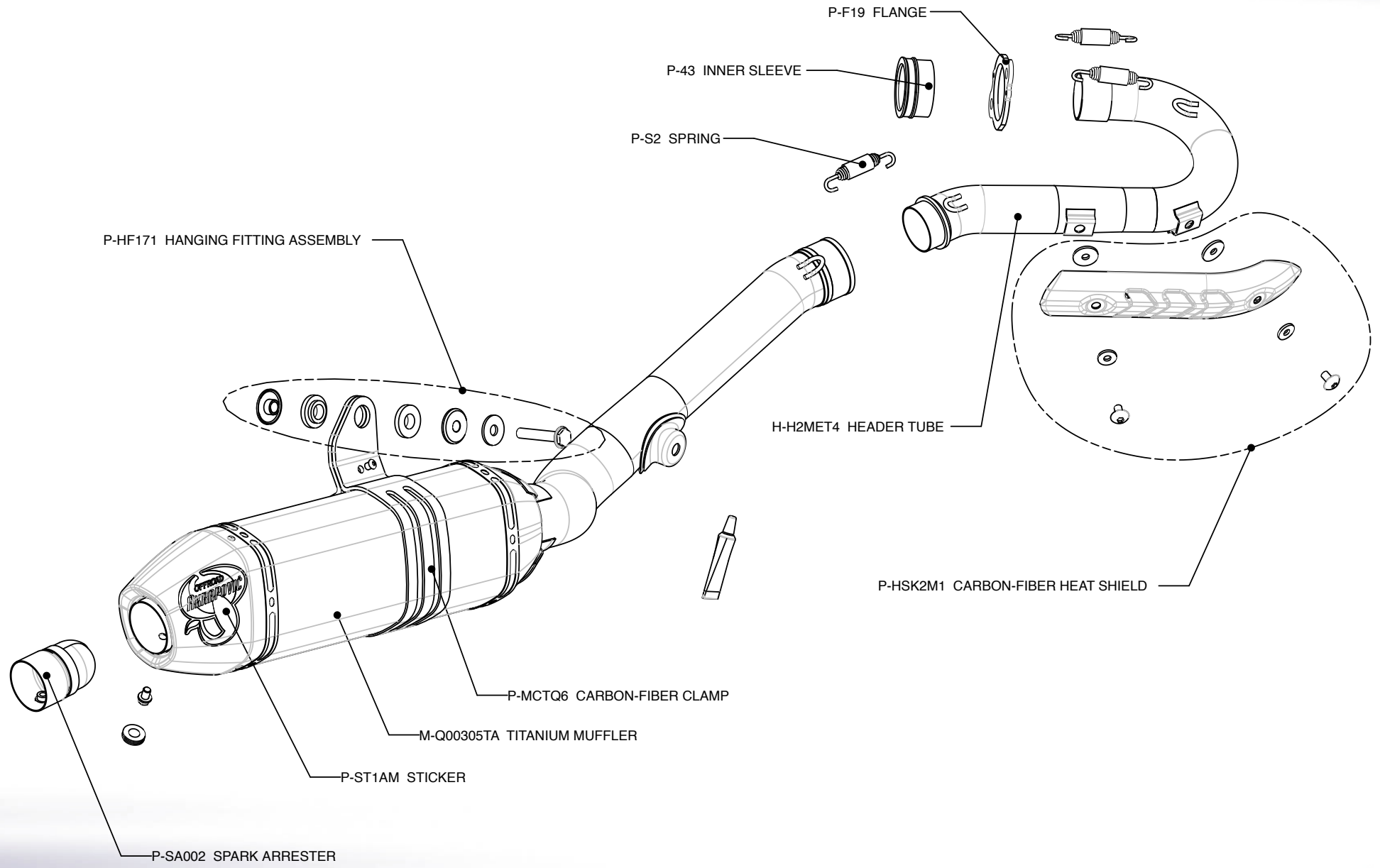

Off-Road Program

Product code: 105151 (S-H2MET4-QTA) US market



Akrapovic Exhaust System Technology copyright 2006, all rights reserved

Akrapovic Racing & Evolution Exhaust System (single muffler)

for the Honda CRF 250R (2006 - 2007)

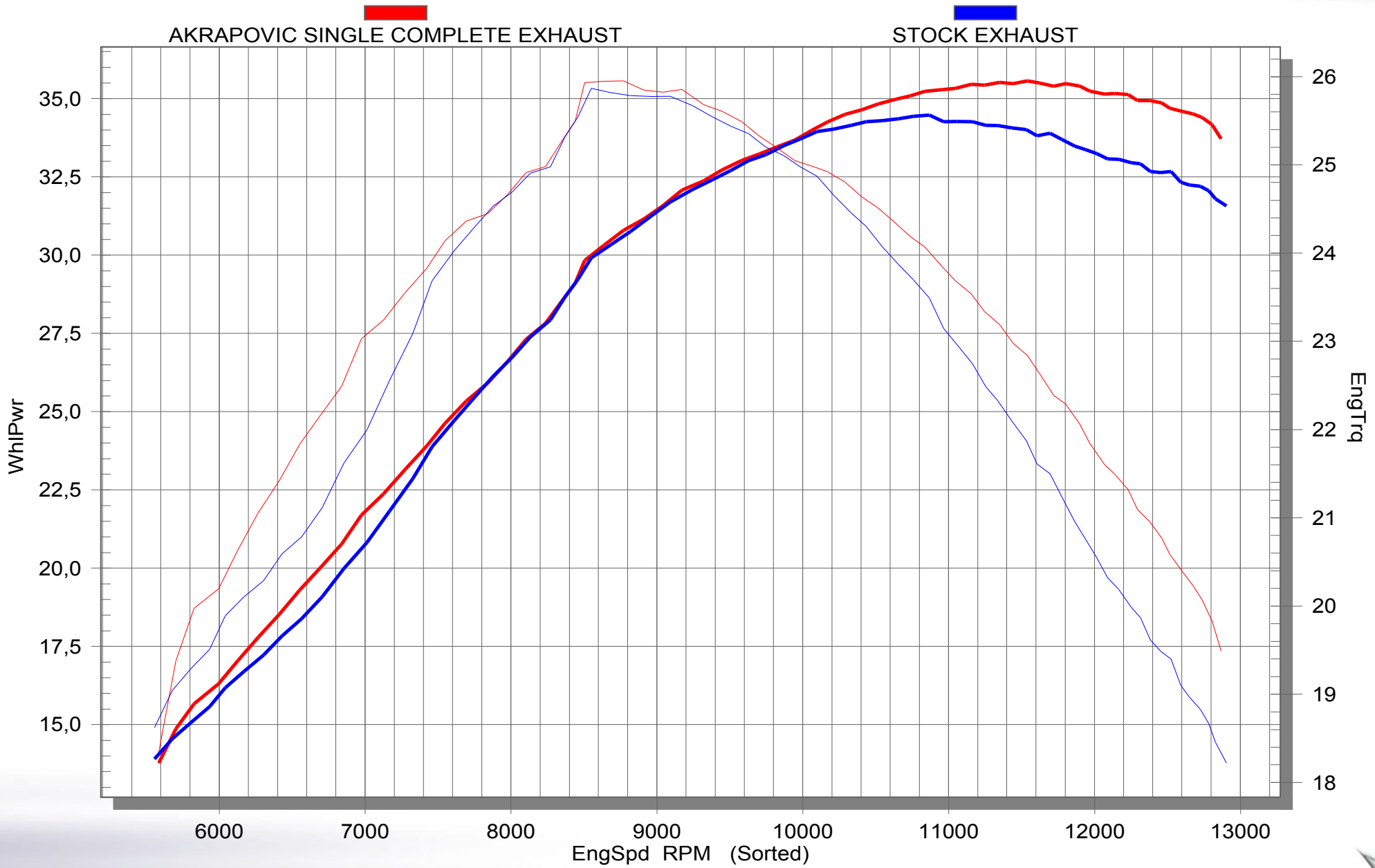

Off-Road Program

Product code: 106667 (S-H2MR4-QT) EU market, 106668 (S-H2MR4-QTA) US market
105174 (S-H2MET4-QT) EU market, 105151 (S-H2MET4-QTA) US market



Akrapovic Exhaust System Technology copyright 2006, all rights reserved