



HONDA CRF 450 F
(2008)

SLIP-ON EXHAUST SYSTEM

www.akrapovic.net

The Akrapovic Slip-On system is designed for recreational Honda CRF 450 enthusiasts. It delivers an excellent combination of quality, performance, visual enhancement, easy installation and affordability. The Akrapovic Slip-On is designed for two markets; in the US it is available with an approved spark arrester, and for the EU and other non-US markets it comes with a noise damper.

PERFORMANCE

Measurements of the Akrapovic SLIP-ON system on the HONDA CRF 450 R (with muffler insert):

Power & Torque: Up to 5600 rpm the Akrapovic Slip-On essentially follows the stock power and torque curves. It shows its true colors above that range, where it delivers significant increases to both power and torque. Max. increased power of 2.8 HP was measured at 6600 rpm. At the top of the rpm range the Akrapovic curves again follow the stock power and torque curves.

CONFIGURATION

The system is composed of a flared stainless steel link pipe which is welded to the muffler. It is attached to the stock header assembly with a sleeve joint secured with a metal clamp. The muffler is the offroad design with a titanium outer sleeve, and stainless steel inlet cap, outlet cap and inner perforation. The muffler is attached to the frame using an Akrapovic carbon-fiber clamp. In the US the system is available with an approved spark arrester, and for the EU and other non-US markets it comes with a standard noise damper.

	PERFORMANCE		
	stock	AKRAPOVIC	max. increased power
max. rear wheel power HP / rpm <small>(measured on Dynojet ATV)</small>	49.2 / 8250	49.7 / 8600	2.8 / 6600

	CONFIGURATION		
	header tubes	collector	link pipe
material	-	-	STAINLESS STEEL
tube shape	-	-	FLARED

interference crossover tubes	-	lambda sensor	-	
header tube inner sleeves	-	header tube flanges	-	
header tubes - collector connection	-	collector / header tube - link pipe connection	SLEEVE JOINT + METAL CLAMP	
link pipe - muffler connection	WELDED	muffler inlet cap /outlet cap	STAINLESS STEEL / STAINLESS STEEL	
muffler metal interior	TITANIUM / STAINLESS STEEL	muffler outer sleeve	TITANIUM	
muffler clamp	CARBON-FIBER	muffler bracket	-	
muffler insert	EU	NOISE DAMPER	heat shield	-
	US	SPARK ARRESTER	catalytic converter	-

	ADDITIONAL DATA				
	stock	AKRAPOVIC		difference	
		S.S. link pipe	TITANIUM link pipe	stock - S.S.	stock - titanium
weight comparison (kg)	2.82	2.14	-	0.68	-
noise measurements (dB / rpm)	stock		AKRAPOVIC		
	94 / 4500		94 / 4500		
possibility of periodic service without removing A.E.S.	oil		oil filter		
	YES		YES		
legal for street use	NO				

Technical specifications of Akrapovic exhaust systems and related products subject to change without notice.



Product code: S-H4SO5-MT
S-H4SO5-MTA



Product code: S-H4SO5-MT
S-H4SO5-MTA



Product code: S-H4SO5-MT
S-H4SO5-MTA

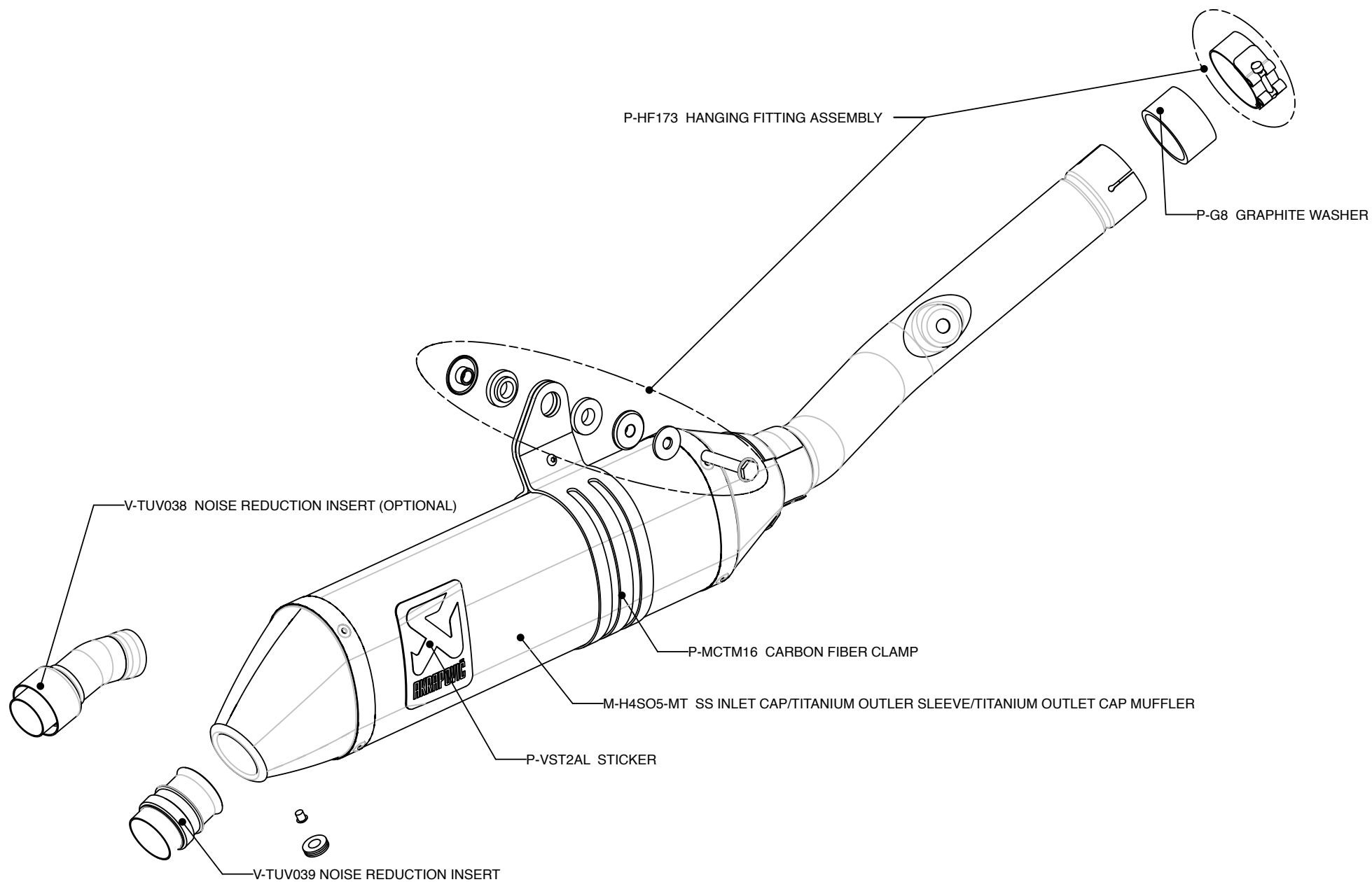

Product code: S-H4SO5-MT
S-H4SO5-MTA

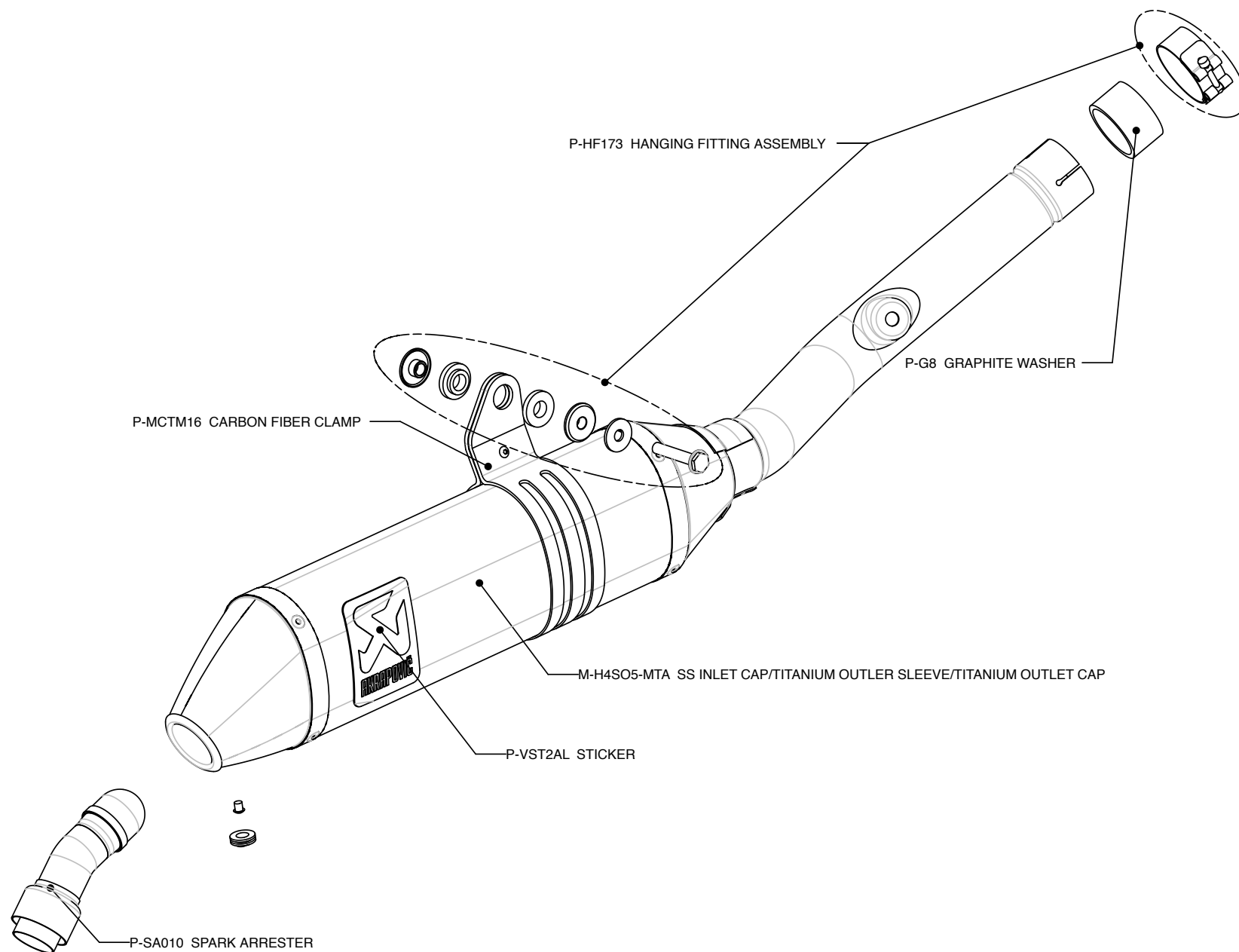

Product code: S-H4SO5-MT
S-H4SO5-MTA

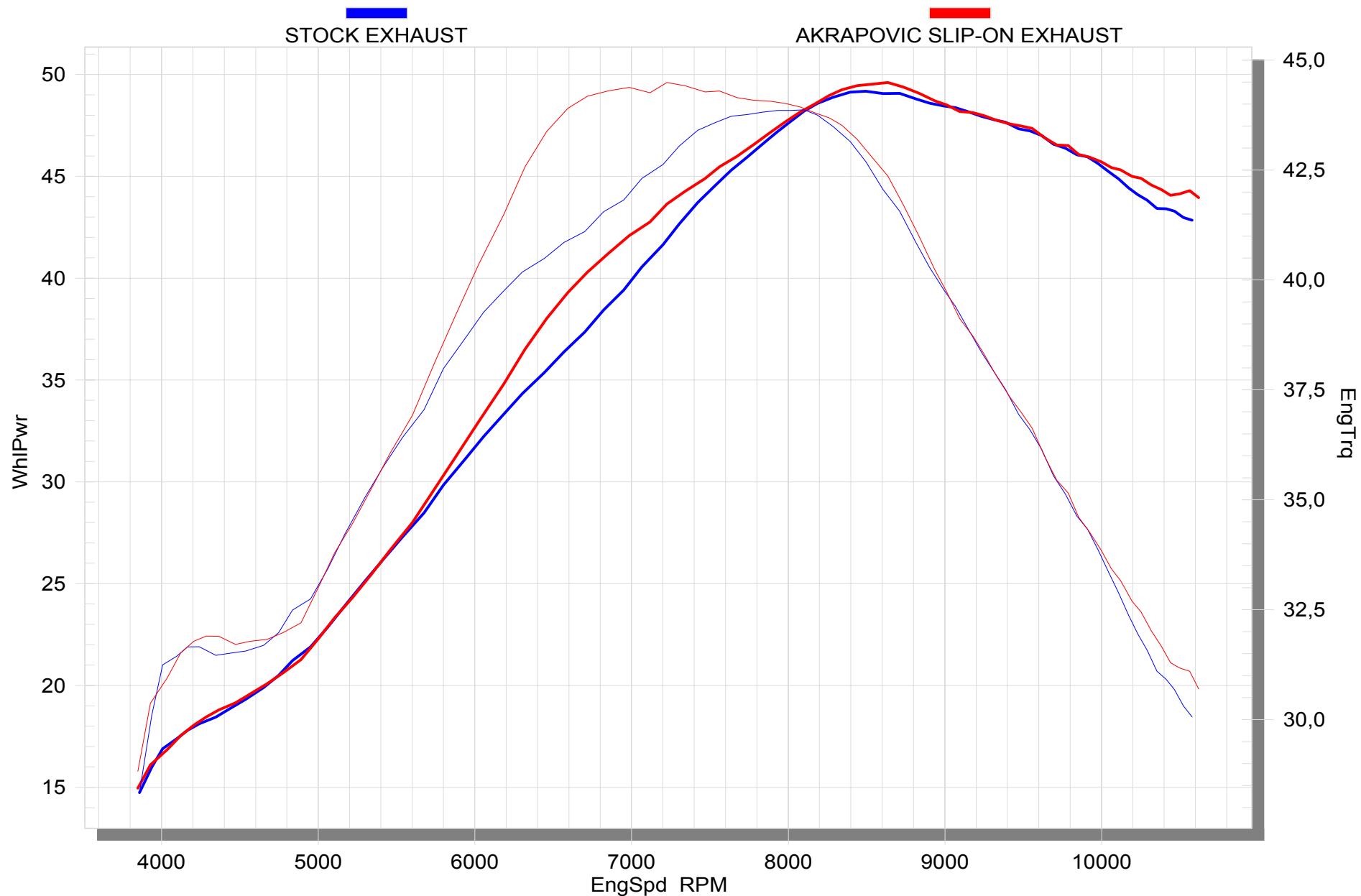

Product code: S-H4SO5-MT
S-H4SO5-MTA