



Kawasaki KX 450 F (2006)

Evolution Exhaust System

Akrapovic Racing & Evolution Exhaust System

for the Kawasaki KX 450 F (2006)

The hexagonal Akrapovic Racing and Evolution represent the best in our offer of exhaust systems. They are intended for professionals and experienced drivers. For those, who expect a maximum from their exhaust system in terms of performance, quality and the visual image. The fitting of one or another system will definitely be noticed on the Kawasaki. It is designed for two markets: for the European and other markets it comes with a built-in noise damper, and for the American market it comes with an approved spark arrester.

PERFORMANCE

Measurements of the Akrapovic EVOLUTION system on the KAWASAKI KX 450 F (with muffler insert):

Power & Torque: the result of fitting one or another system is substantial. The value of the power and torque is strengthened throughout the complete range of engine rpm. The increase of power is evident from middle rpm onwards and stretching well into the overrev range.

CONFIGURATION

Akrapovic Racing and Evolution systems are of a recognised Hexagonal off-road form. They differ only in terms of the material of the pipe: we use stainless steel for Racing and titanium for Evolution. The header tube is conical, made from stainless steel (Racing) or titanium (Evolution). It is jointed with a conical SS/titanium link pipe by a sleeve joint, which is secured with a silicon-shielded spring. The link pipe is welded to the muffler. The inlet cap, due to the method of connection with the link pipe, is made from stainless steel (Racing) or titanium (Evolution), same for the internal perforation. The outlet cap is in both cases made of carbon. The outer sleeve of the muffler is available either made from titanium or carbon fibres. The system is attached to the motorcycle with the aid of Akrapovic carbon fibre clamps. The Akrapovic carbon fibre heat shield is also intended for this system. The system comes with a built-in noise damper for the European and other markets, and an approved spark arrester for the American market, which is marked with a laser engraving.

	PERFORMANCE		
	stock	AKRAPOVIC	max. increased power
max. rear wheel power HP / rpm (measured on Dynojet ATV)	49.8 / 8600	51.2 / 8900	4.7 / 10600

	CONFIGURATION		
	header tubes	collector	link pipe
material	TITANIUM (Evolution) STAINLESS STEEL (Racing)	-	TITANIUM (Evolution) STAINLESS STEEL (Racing)
tube shape	CONICAL	-	CONICAL

interference crossover tubes	-	lambda sensor	-	
header tube inner sleeves	S.S. CNC MACHINED	header tube flanges	S.S. LASER CUT	
header tubes - collector connection	-	collector / header tube - link pipe connection	SLEEVE JOINT + SILICON SHIELDED SPRING	
link pipe - muffler connection	WELDED	muffler inlet cap / outlet cap	TITANIUM (Evolution), STAINLESS STEEL (Racing) / CARBON-FIBER (Evolution & Racing)	
muffler metal interior	TITANIUM (Evolution) STAINLESS STEEL (Racing)	muffler outer sleeve	TITANIUM CARBON-FIBER	
muffler clamp	CARBON-FIBER	muffler bracket	-	
muffler insert	EU	NOISE DAMPER	heat shield	CARBON FIBER
	US	SPARK ARRESTER	catalytic converter	-

	ADDITIONAL DATA				
	stock	AKRAPOVIC		difference	
weight comparison (kg)	3.39	RACING	EVOLUTION	stock - RACING	stock - EVOLUTION
		2.76	2.45	0.63	0.94
noise measurements (dB / rpm)	stock		AKRAPOVIC		
	96 / 4500		96 / 4500		
possibility of periodic service without removing A.E.S.	oil		oil filter		
	YES		YES		
legal for street use	NO				

Technical specifications of Akrapovic exhaust systems and related products subject to change without notice.

Product code: 10049 (S-K4MR2-QT), 107042 (S-K4MET2-QT)
107048 (S-K4MR2-QTA), 107043 (S-K4MET2-QTA) US market

Akrapovic Racing & Evolution Exhaust System for the Kawasaki KX 450 F (2006)

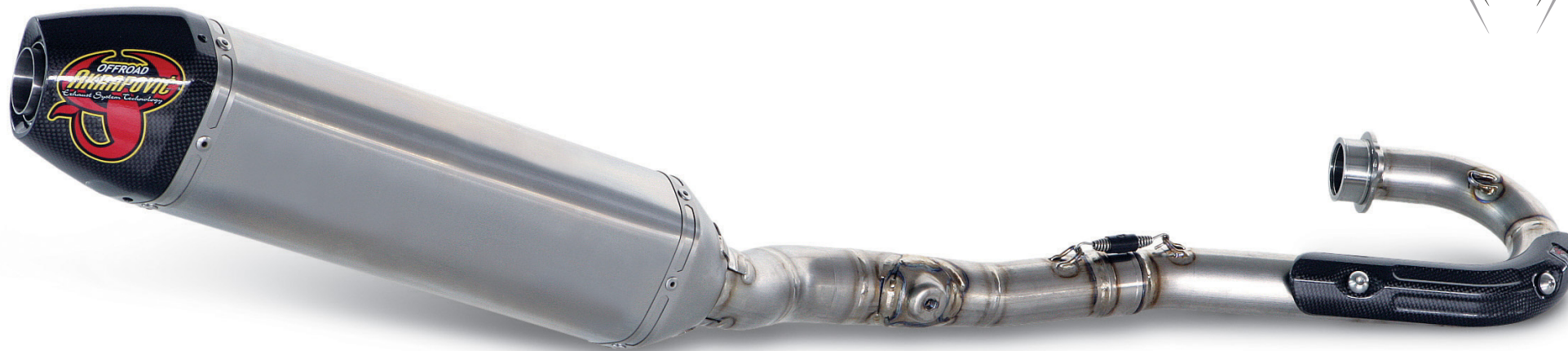

CARBON-FIBER
MUFFLER CLAMP

Off-Road
Program

Product code: 10049 (S-K4MR2-QT), 107042 (S-K4MET2-QT)
107048 (S-K4MR2-QTA), 107043 (S-K4MET2-QTA) US market

Akrapovic Racing & Evolution Exhaust System

for the Kawasaki KX 450 F (2006)



Akrapovic Exhaust System Technology copyright 2006, all rights reserved

Off-Road
Program

Product code: 10049 (S-K4MR2-QT), 107042 (S-K4MET2-QT)
107048 (S-K4MR2-QTA), 107043 (S-K4MET2-QTA) US market

Akrapovic Racing & Evolution Exhaust System for the Kawasaki KX 450 F (2006)



Akrapovic Exhaust System Technology copyright 2006, all rights reserved

Off-Road
Program

Product code: 10049 (S-K4MR2-QT), 107042 (S-K4MET2-QT)
107048 (S-K4MR2-QTA), 107043 (S-K4MET2-QTA) US market

Akrapovic Racing & Evolution Exhaust System

for the Kawasaki KX 450 F (2006)

**KAWASAKI KX 450 F Complete Exhaust System,
Racing line, Model Year: 2006 - 2007**

Product code: S-K4MR2-QT

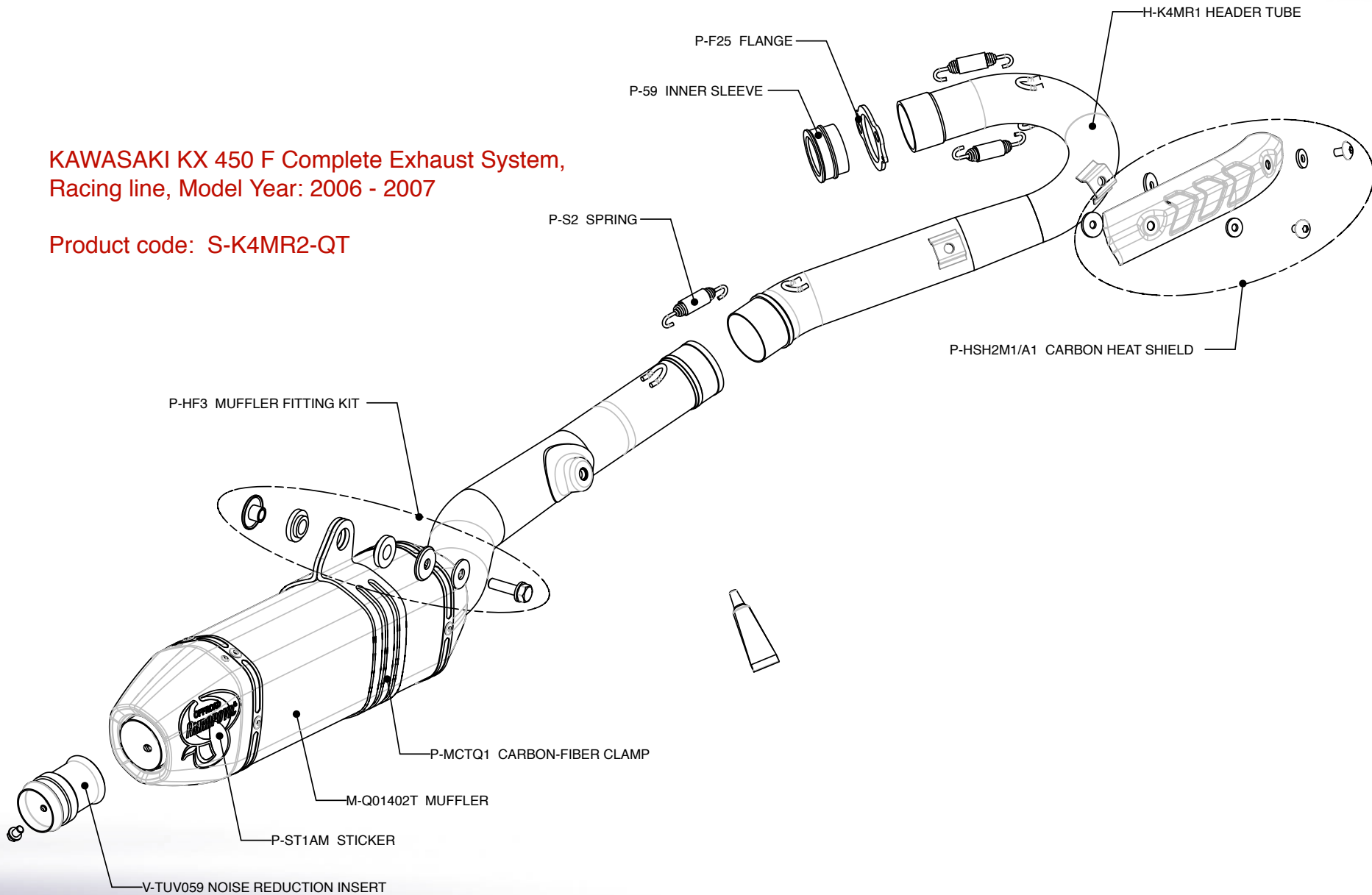

Akrapovic Exhaust System Technology copyright 2006, all rights reserved

Off-Road Program

Product code: 10049 (S-K4MR2-QT), 107042 (S-K4MET2-QT)
107048 (S-K4MR2-QTA), 107043 (S-K4MET2-QTA) US market

Akrapovic Racing & Evolution Exhaust System

for the Kawasaki KX 450 F (2006)

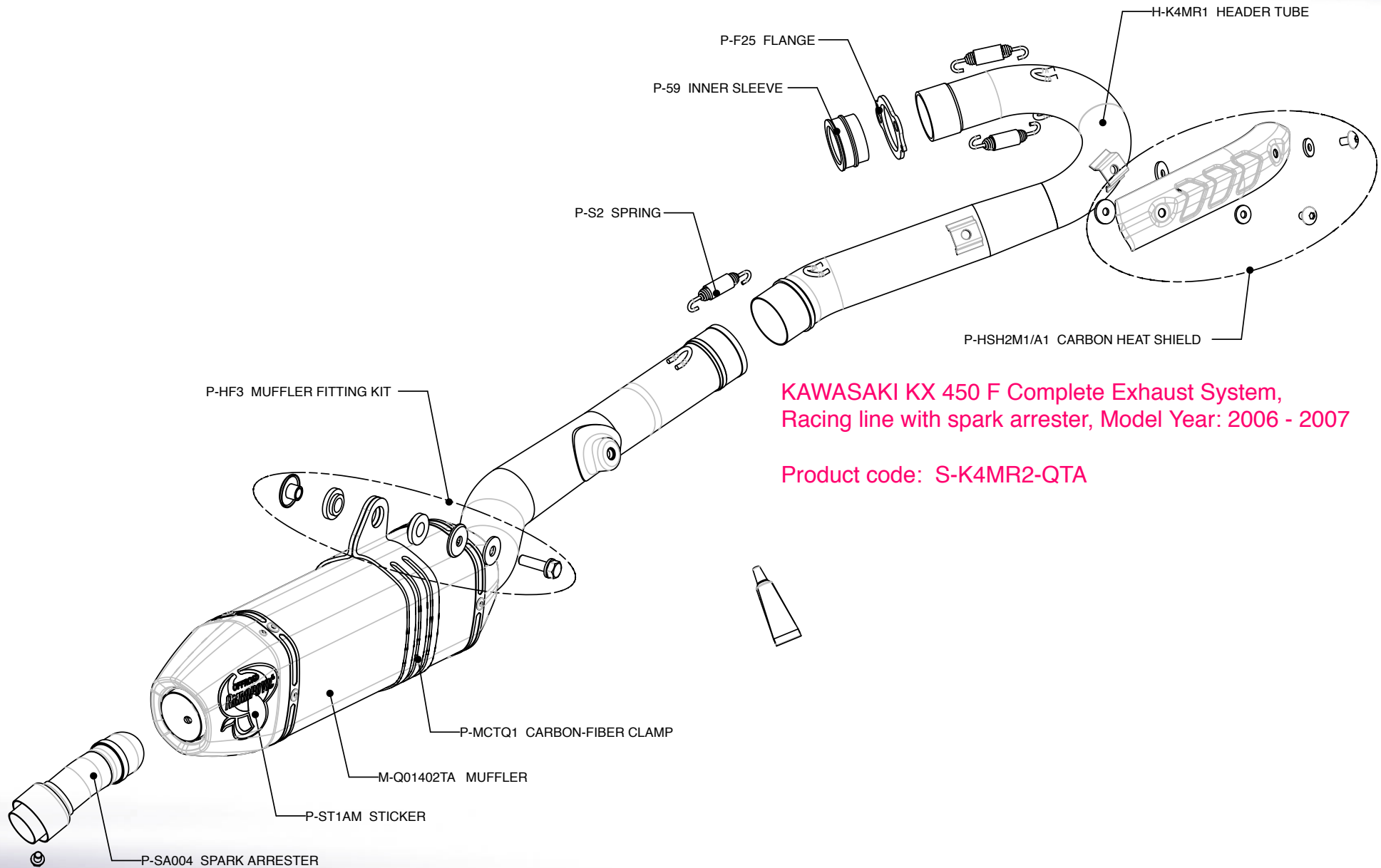

**KAWASAKI KX 450 F Complete Exhaust System,
Racing line with spark arrester, Model Year: 2006 - 2007**

Product code: S-K4MR2-QTA

Akrapovic Exhaust System Technology copyright 2006, all rights reserved

Off-Road Program

Product code: 10049 (S-K4MR2-QT), 107042 (S-K4MET2-QT)
107048 (S-K4MR2-QTA), 107043 (S-K4MET2-QTA) US market



Akrapovic Racing & Evolution Exhaust System

for the Kawasaki KX 450 F (2006)

KAWASAKI KX 450 F Complete Exhaust System,
Evolution line, Model Year: 2006 - 2007

Product code: S-K4MET2-QT

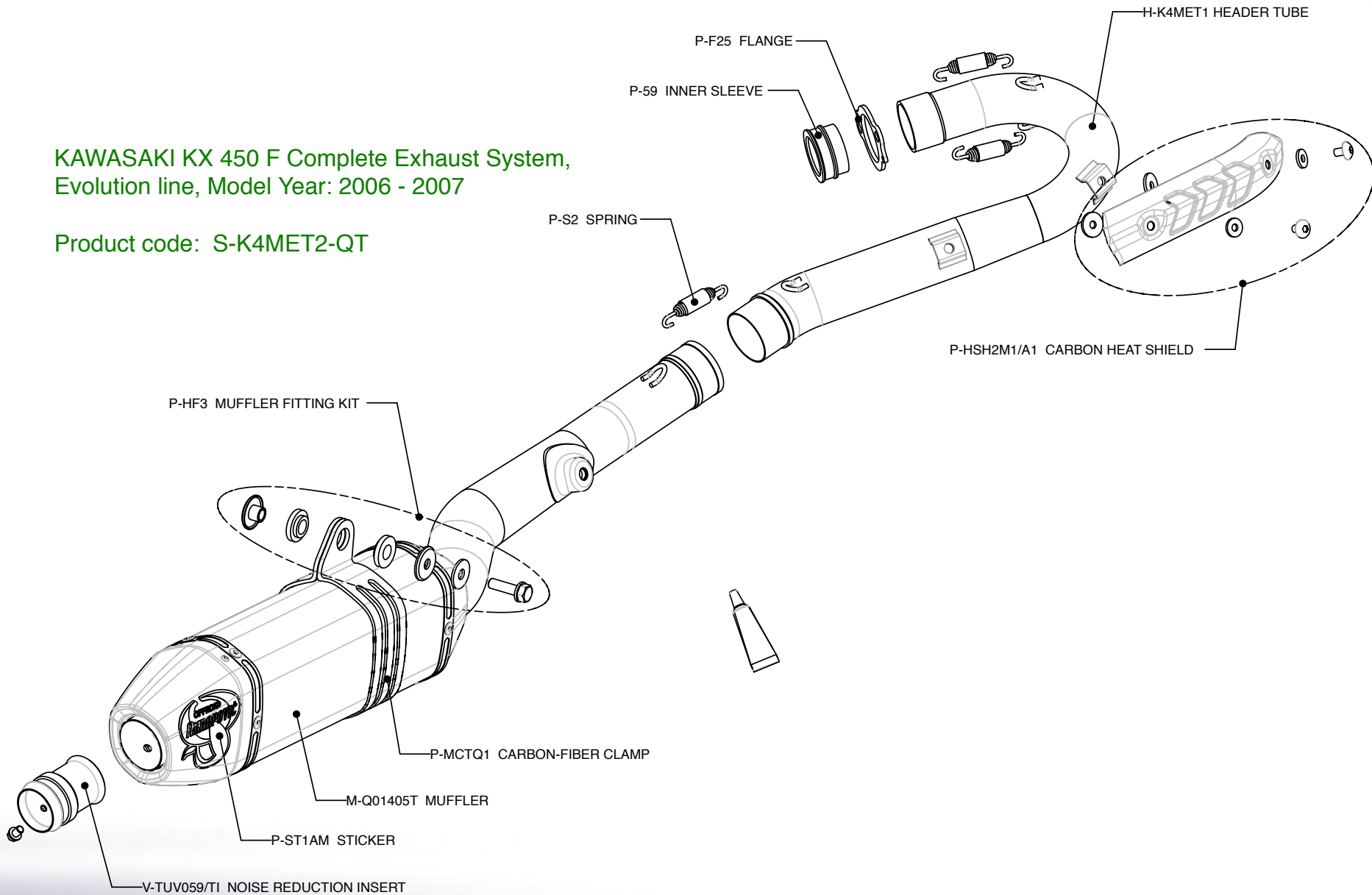

Akrapovic Exhaust System Technology copyright 2006, all rights reserved

Off-Road
Program

Product code: 10049 (S-K4MR2-QT), 107042 (S-K4MET2-QT)
107048 (S-K4MR2-QTA), 107043 (S-K4MET2-QTA) US market

Akrapovic Racing & Evolution Exhaust System

for the Kawasaki KX 450 F (2006)

KAWASAKI KX 450 F Complete Exhaust System,
Evolution line with spark arrester, Model Year: 2006 - 2007

Product code: S-K4MET2-QTA

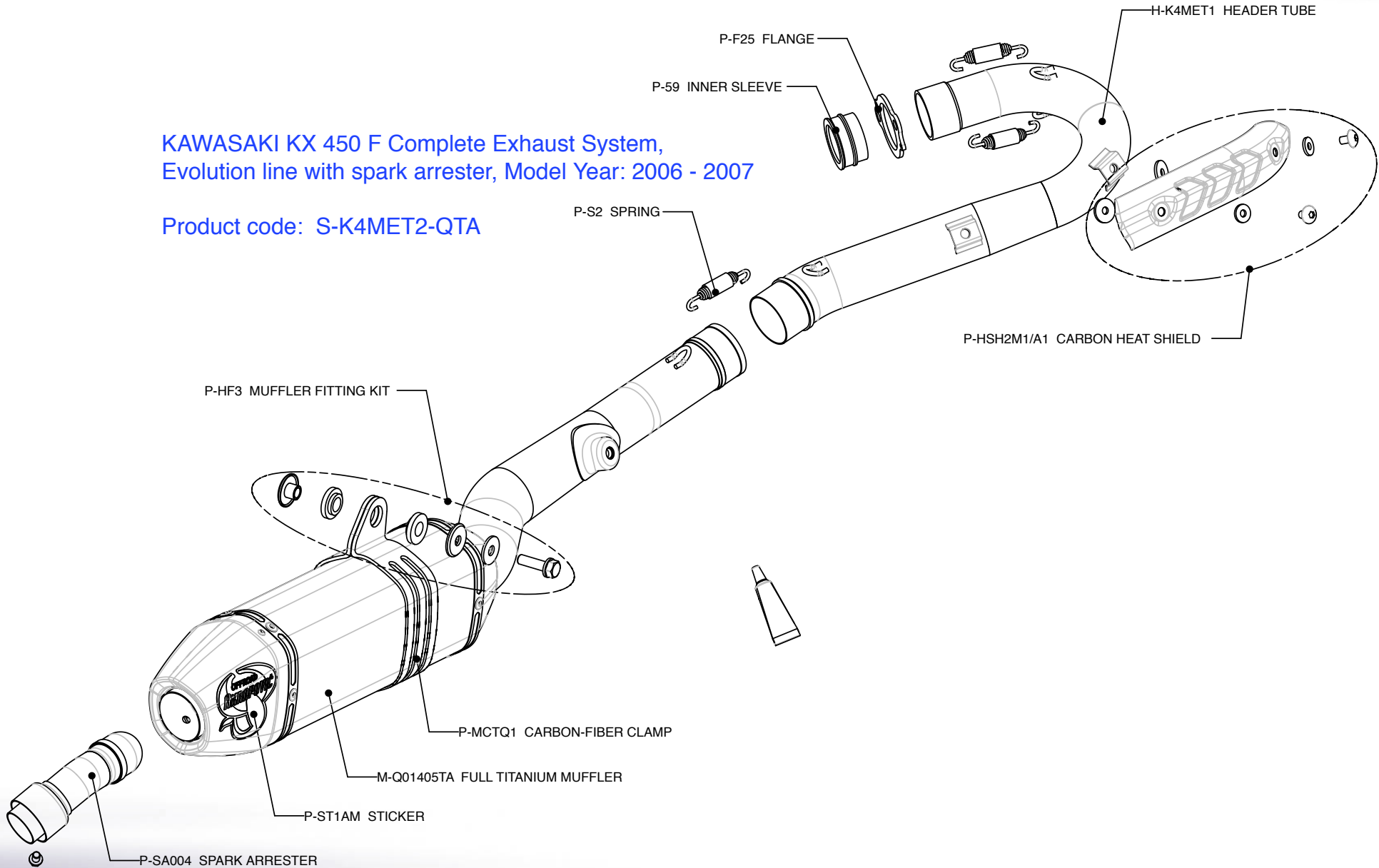

Off-Road
Program

Product code: 10049 (S-K4MR2-QT), 107042 (S-K4MET2-QT)
107048 (S-K4MR2-QTA), 107043 (S-K4MET2-QTA) US market

Akrapovic Racing & Evolution Exhaust System

for the Kawasaki KX 450 F (2006)

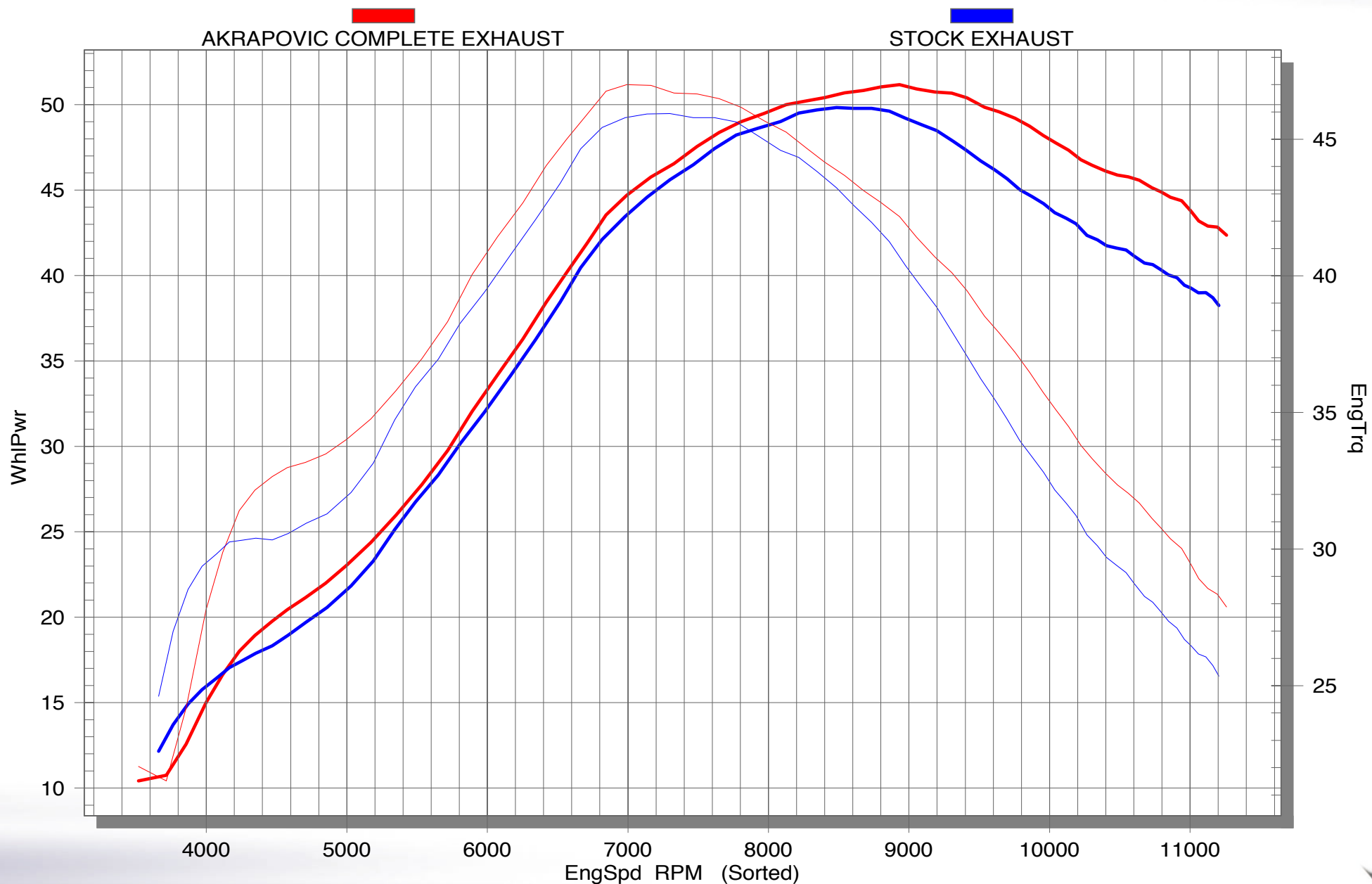

Akrapovic Exhaust System Technology copyright 2006, all rights reserved

Off-Road Program

Product code: 10049 (S-K4MR2-QT), 107042 (S-K4MET2-QT)
107048 (S-K4MR2-QTA), 107043 (S-K4MET2-QTA) US market

