



Kawasaki ZZR 1400 (2006)

Slip-On SP Series Exhaust System

# Akrapovic Slip-On SP Series Exhaust System

## for the Kawasaki ZZR 1400 (2006)

The Akrapovic Slip-On SP Series (open) is designed for riders who do not require an extreme performance upgrade, but who are looking for an excellent combination of production quality, affordability and of course increased performance, with a simple exhaust system modification. The Akrapovic Slip-On SP Series will definitely satisfy ZZR riders, since the stock motorcycle already offers huge amounts of power and torque, and together with Akrapovic it can only get better. The system includes a noise damper. The system is not homologated for street use.

### PERFORMANCE

Measurements of the Akrapovic SLIP-ON SP SERIES system on the KAWASAKI ZZR 1400 (without muffler insert):

Power & Torque: the Akrapovic Slip-On SP series is a base-level exhaust system modification. However, it delivers a surprisingly solid increase in engine performance, as can be seen from the power and torque figures. We have managed to smooth out the power and torque curves in order to provide more even performance. At 9800 rpm we measured 176.7 HP, and max. increased power of 4.8 HP was measured at the same engine speed.

### CONFIGURATION

The Akrapovic SLIP-ON SP SERIES exhaust system is composed of a stainless steel link pipe and muffler. Sleeve joints are used for both the link pipe – muffler joint and the link pipe – stock header assembly joint. The joint with the stock header assembly is secured with a metal clamp and a silicon-shielded spring, while the muffler joint is secured solely with silicon-shielded springs. Except for the outer sleeve, which is available only in titanium, the component parts of the muffler – the inlet cap, perforated inner sleeve and outlet cap – are made of stainless steel. The muffler is attached to the frame with an Akrapovic carbon fiber clamp. The muffler has installed a non-homologated noise damper. It also includes a catalytic converter.

	PERFORMANCE		
	stock	AKRAPOVIC	max. increased power
max. rear wheel power HP / rpm (measured on Dynojet ATV)	172.2 / 9630	176.7 / 9817	4.8 / 9800

	CONFIGURATION		
	header tubes	collector	link pipe
material	-	-	STAINLESS STEEL
tube shape	-	-	FLARED

interference crossover tubes	-	lambda sensor	-	
header tube inner sleeves	-	header tube flanges	-	
header tubes - collector connection	-	collector / header tube - link pipe connection	SLEEVE JOINT+ METAL CLAMP + SILICON SHIELDED SPRING	
link pipe - muffler connection	SLEEVE JOINT + SILICON SHIELDED SPRING	muffler inlet cap / outlet cap	STAINLESS STEEL / STAINLESS STEEL	
muffler metal interior	STAINLESS STEEL	muffler outer sleeve	TITANIUM	
muffler clamp	CARBON-FIBER ROAD	muffler bracket	-	
muffler insert	EU	NOISE DAMPER	heat shield	-
	US	-	catalytic converter	YES

	ADDITIONAL DATA				
	stock	AKRAPOVIC		difference	
		S.S. link pipe	TITANIUM link pipe	stock - S.S.	stock - titanium
weight comparison (kg)	13.19	4.90	-	8.29	-

noise measurements (dB / rpm)	stock	AKRAPOVIC
	97 / 4750	97 / 4750
possibility of periodic service without removing A.E.S.	oil	oil filter
	YES	YES
legal for street use	NO	

Technical specifications of Akrapovic exhaust systems and related products subject to change without notice.

Product code: 106417 (SS-K14S01-T)  
106418 (SS-K14S01-C)

# Akrapovic Slip-On SP Series Exhaust System for the Kawasaki ZZR 1400 (2006)



CARBON-FIBER  
MUFFLER CLAMP

Product code: 106417 (SS-K14S01-T)  
106418 (SS-K14S01-C)

# Akrapovic Slip-On SP Series Exhaust System for the Kawasaki ZZR 1400 (2006)



Akrapovic Exhaust System Technology copyright 2006, all rights reserved

Road  
Program

Product code: 106417 (SS-K14S01-T)  
106418 (SS-K14S01-C)

# Akrapovic Slip-On SP Series Exhaust System for the Kawasaki ZZR 1400 (2006)



Akrapovic Exhaust System Technology copyright 2006, all rights reserved

Road Program

Product code: 106417 (SS-K14S01-T)  
106418 (SS-K14S01-C)

# Akrapovic Slip-On SP Series Exhaust System

for the Kawasaki ZZR 1400 (2006)

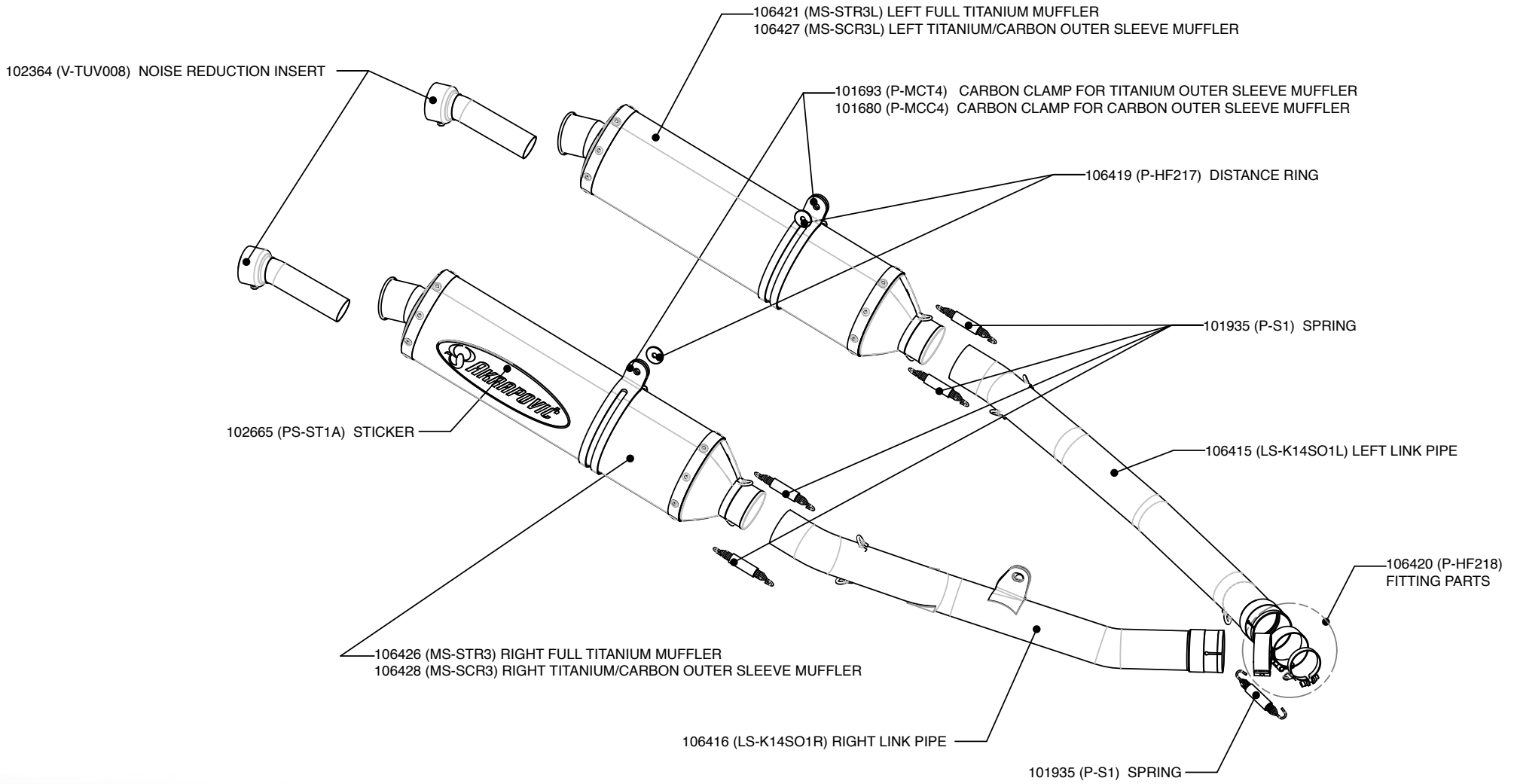

Road Program

Product code: 106417 (SS-K14SO1-T)  
106418 (SS-K14SO1-C)



Akrapovic Exhaust System Technology copyright 2006, all rights reserved

# Akrapovic Slip-On SP Series Exhaust System

for the Kawasaki ZZR 1400 (2006)

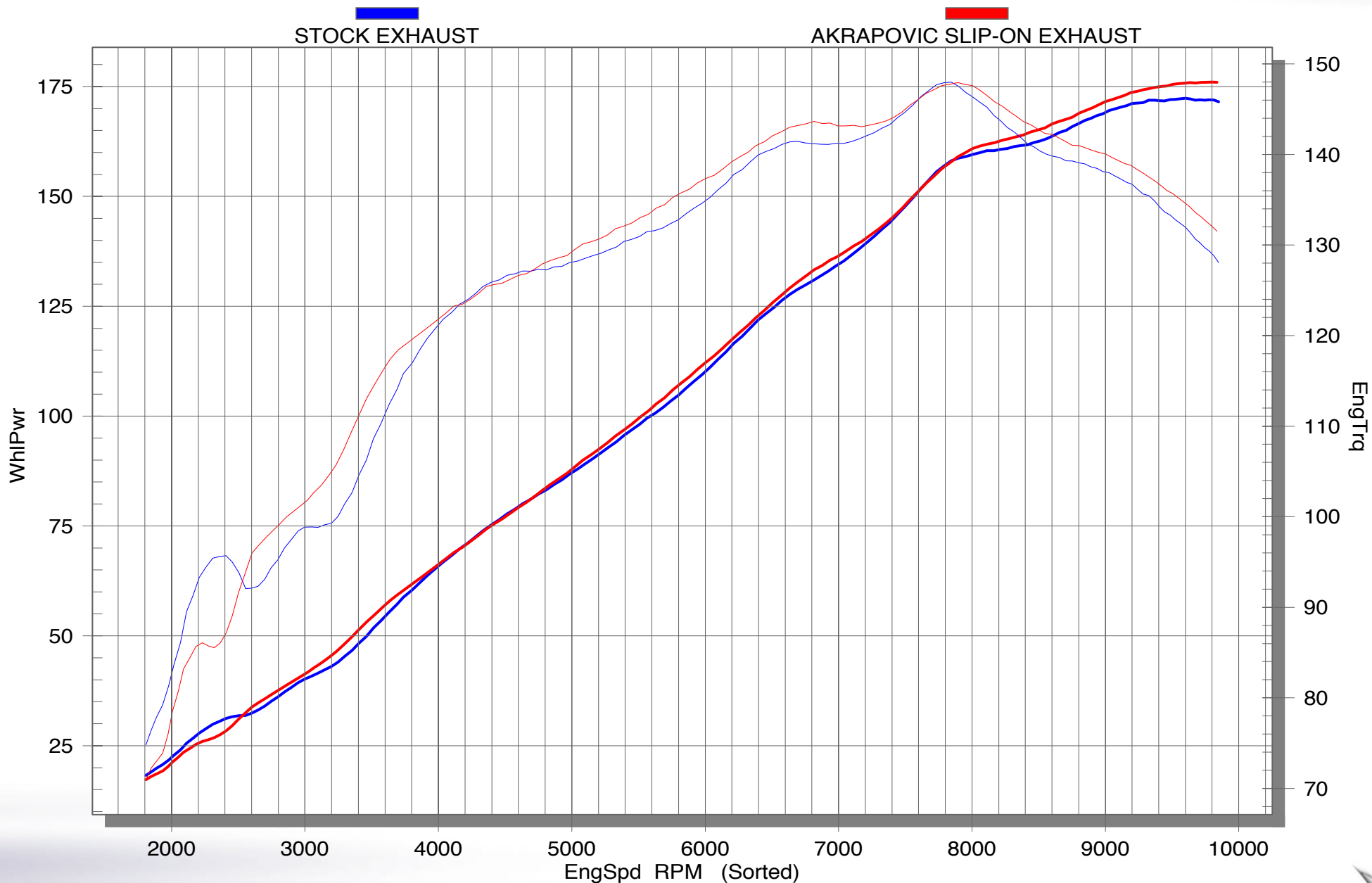

Road Program

Product code: 106417 (SS-K14S01-T)  
106418 (SS-K14S01-C)

