



Suzuki RM-Z 450 (2007)

Racing & Evolution Exhaust System

# Akrapovic Racing & Evolution Exhaust System

for the Suzuki RM-Z 450 (2007)

Akrapovic Racing or Evolution with the modern HEXAGONAL form of the muffler brilliantly emphasizes the outer line of the RM-Z. Because the system is intended for those, who expect the most, it offers, alongside the visual image, a performance upgrade of the engine. They are designed for two markets: for the European and other markets they come with a built-in noise damper, and for the American market they come with an approved spark arrester.

## PERFORMANCE

Measurements of the Akrapovic EVOLUTION system on the SUZUKI RM-Z 450 (with muffler insert):

Power & Torque: Racing or Evolution, regardless of the choice (the difference is in fact only in the exhaust pipe material), are both systems which fit brilliantly with the pulse of the Suzuki engine. The fitting of the complete system enriches the value of power and torque over the entire range of engine rotation, most in the lowest and highest rpm areas. At 8300 rpm, we measured 49.1 HP at the back wheel.

## CONFIGURATION

The Akrapovic Racing and Evolution systems for the 2007 Suzuki RM-Z 450 are composed of conical header tube attached to the conical link pipe with a sleeve joint, which is secured with a silicon-shielded spring. They differ only in their selection of tubing materials. The Racing uses stainless steel tubes, and the Evolution titanium. The link pipe is welded to the muffler.

The muffler is the HEXAGONAL design, with a titanium (Evolution) or stainless steel (Racing) inlet cap, titanium (Evolution) or stainless steel (Racing) perforated inner sleeve and titanium outer sleeve (both versions), and a carbon-fibre outlet cap (both versions). The muffler is attached to the frame using an Akrapovic off-road carbon-fibre clamp.

In case of the Racing version either the stock heat shield or the optional Akrapovic carbon-fibre heat shield can be mounted on the header tube. Evolution is equipped with the carbon-fibre heat shield as a standard. The muffler is designed for two markets: for the European and other markets it comes with a built-in noise damper, and for the American market it comes with an approved spark arrester.

	PERFORMANCE		
	stock	AKRAPOVIC	max. increased power
max. rear wheel power HP / rpm (measured on Dynojet ATV)	47.9 / 8300	49.1 / 8500	4.4. / 10100

	CONFIGURATION		
	header tubes	collector	link pipe
material	TITANIUM (Evolution) STAINLESS STEEL (Racing)	-	TITANIUM (Evolution) STAINLESS STEEL (Racing)
tube shape	CONICAL	-	CONICAL

interference crossover tubes	NO	lambda sensor	-	
header tube inner sleeves	S.S. CNC MACHINED	header tube flanges	S.S. LASER CUT	
header tubes - collector connection	-	collector / header tube - link pipe connection	SLEEVE JOINT + SILICON SHIELDED SPRING	
link pipe - muffler connection	WELDED	muffler inlet cap / outlet cap	TITANIUM (Evolution) STAINLESS STEEL (Racing) / CARBON-FIBER	
muffler metal interior	TITANIUM (Evolution) STAINLESS STEEL (Racing)	muffler outer sleeve	TITANIUM	
muffler clamp	CARBON-FIBER OFF ROAD	muffler bracket	-	
muffler insert	EU	NOISE DAMPER	heat shield	Optional for racing only!
	US	SPARK ARRESTER	catalytic converter	NO

	ADDITIONAL DATA				
	stock	AKRAPOVIC		difference	
weight comparison (kg)	3.6	RACING	EVOLUTION	stock - RACING	stock - EVOLUTION
		2.80	2.44	0.806	1.16
noise measurements (dB / rpm)	stock		AKRAPOVIC		
	96 / 4500		96 / 4500		
possibility of periodic service without removing A.E.S.	oil		oil filter		
	YES		YES		
legal for street use	NO				

Technical specifications of Akrapovic exhaust systems and related products subject to change without notice.

Product code: 107115 (S-S4MR5-QT), 107116 (S-S4MR5-QTA) US market  
107113 (S-S4MET5-QT), 107114 (S-S4MET5-QTA) US market

# Akrapovic Racing & Evolution Exhaust System for the Suzuki RM-Z 450 (2007)



CARBON-FIBER  
MUFFLER CLAMP

Akrapovic Exhaust System Technology copyright 2007, all rights reserved

Off-Road  
Program

Product code: 107115 (S-S4MR5-QT), 107116 (S-S4MR5-QTA) US market  
107113 (S-S4MET5-QT), 107114 (S-S4MET5-QTA) US market

# Akrapovic Racing & Evolution Exhaust System for the Suzuki RM-Z 450 (2007)



Akrapovic Exhaust System Technology copyright 2007, all rights reserved

Off-Road  
Program

Product code: 107115 (S-S4MR5-QT), 107116 (S-S4MR5-QTA) US market  
107113 (S-S4MET5-QT), 107114 (S-S4MET5-QTA) US market

# Akrapovic Racing & Evolution Exhaust System for the Suzuki RM-Z 450 (2007)



Akrapovic Exhaust System Technology copyright 2007, all rights reserved

Off-Road  
Program

Product code: 107115 (S-S4MR5-QT), 107116 (S-S4MR5-QTA) US market  
107113 (S-S4MET5-QT), 107114 (S-S4MET5-QTA) US market

# Akrapovic Racing Exhaust System

for the Suzuki RM-Z 450 (2007)

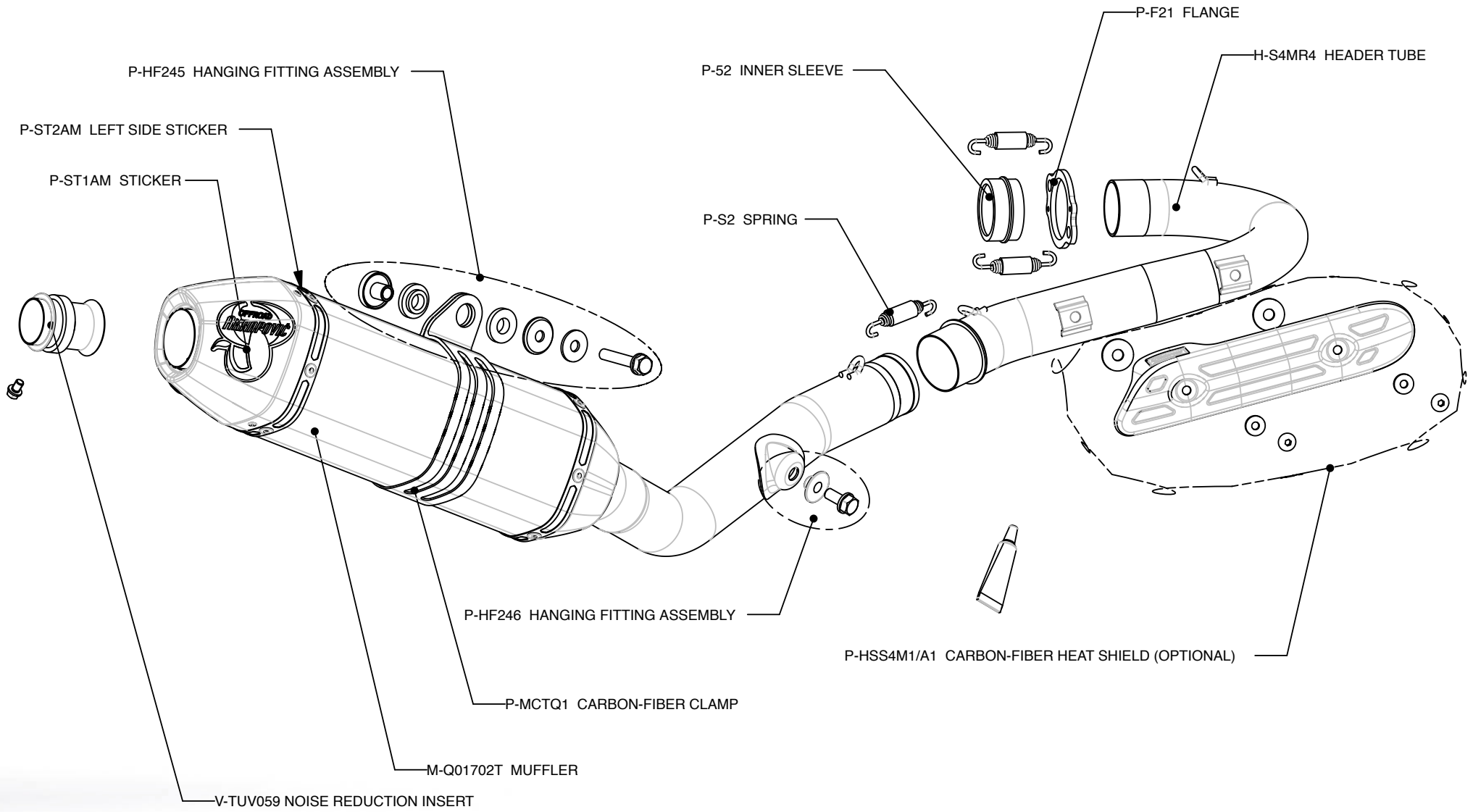

Akrapovic Exhaust System Technology copyright 2007, all rights reserved

Off-Road Program

Product code: 107115 (S-S4MR5-QT)



# Akrapovic Racing Exhaust System for the Suzuki RM-Z 450 (2007)

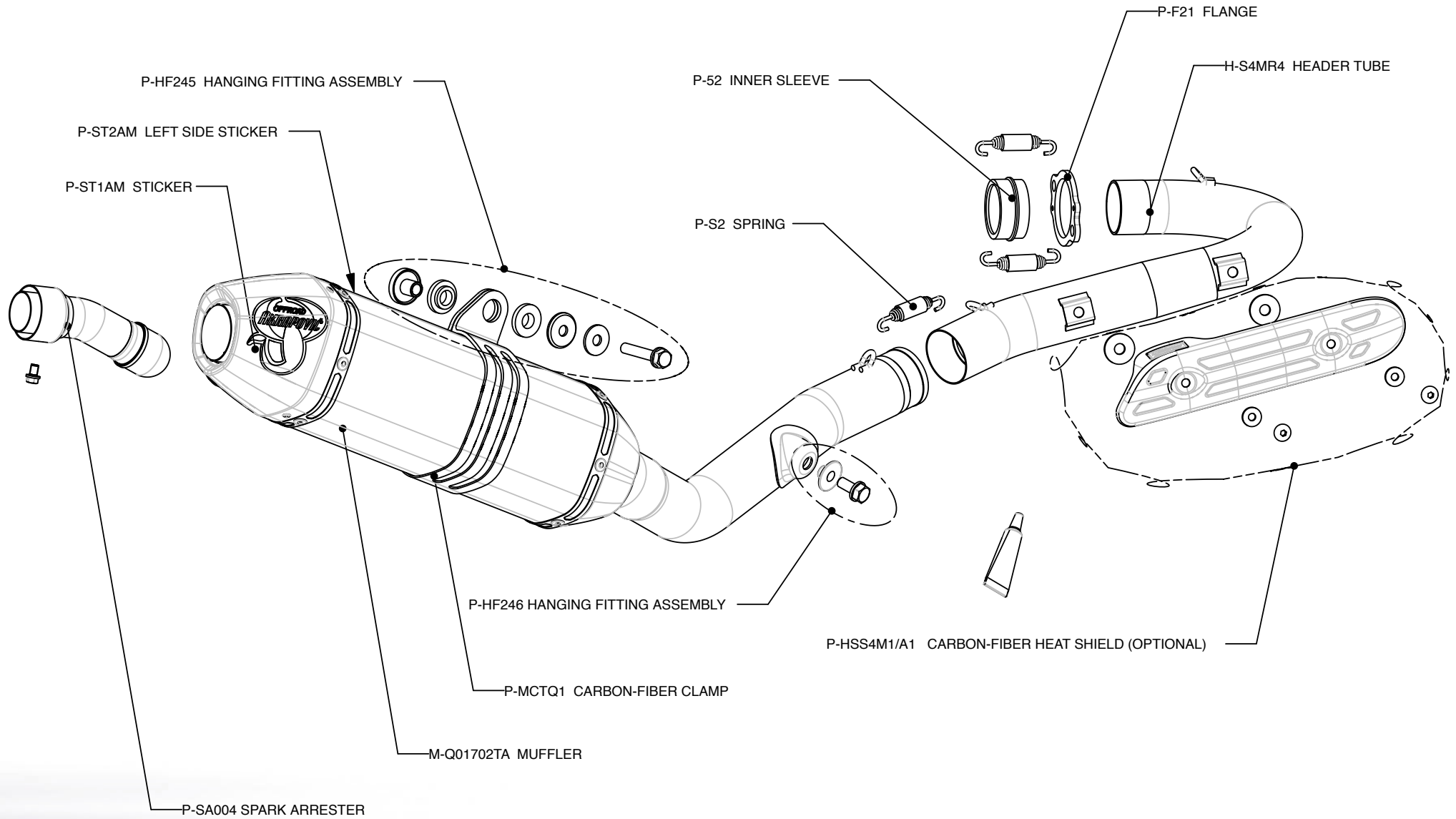

Akrapovic Exhaust System Technology copyright 2007, all rights reserved

Off-Road Program

Product code: 107116 (S-S4MR5-QTA) US market



# Akrapovic Evolution Exhaust System for the Suzuki RM-Z 450 (2007)

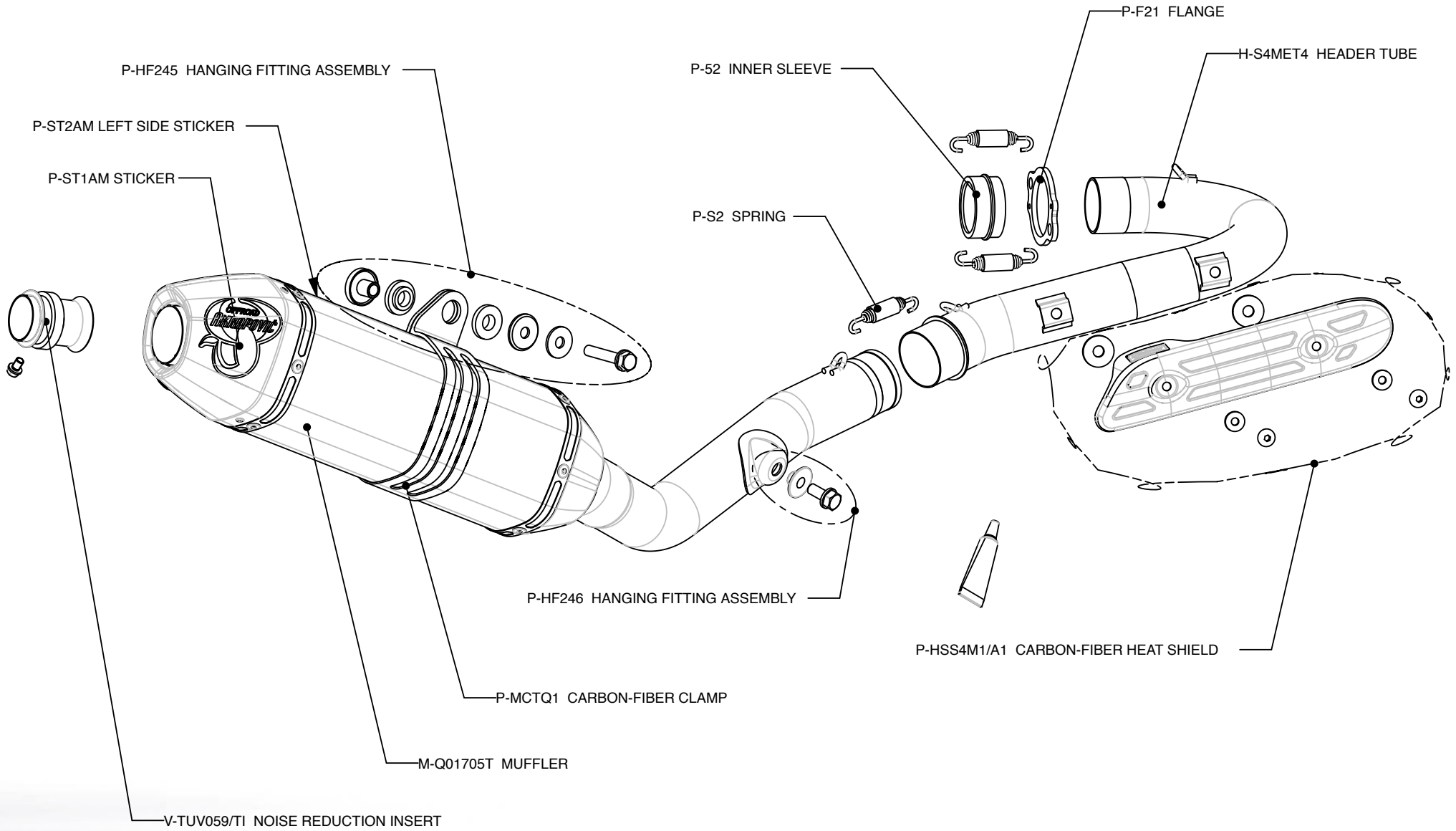

Off-Road  
Program

Product code: 107113 (S-S4MET5-QT)



Akrapovic Exhaust System Technology copyright 2007, all rights reserved

# Akrapovic Evolution Exhaust System for the Suzuki RM-Z 450 (2007)

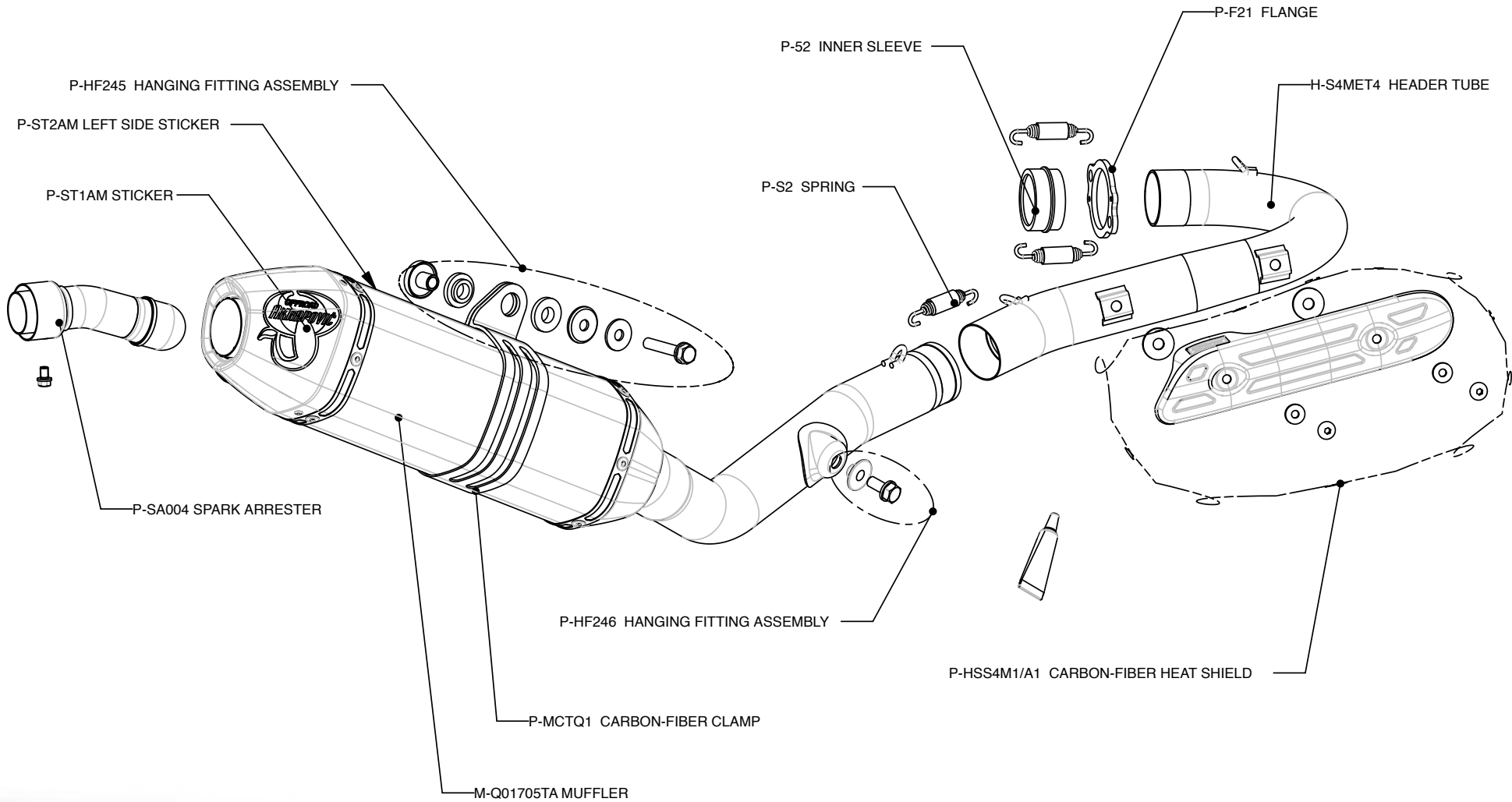

Akrapovic Exhaust System Technology copyright 2007, all rights reserved

Off-Road  
Program

Product code: 107114 (S-S4MET5-QTA) US market

# Akrapovic Racing & Evolution Exhaust System

for the Suzuki RM-Z 450 (2007)

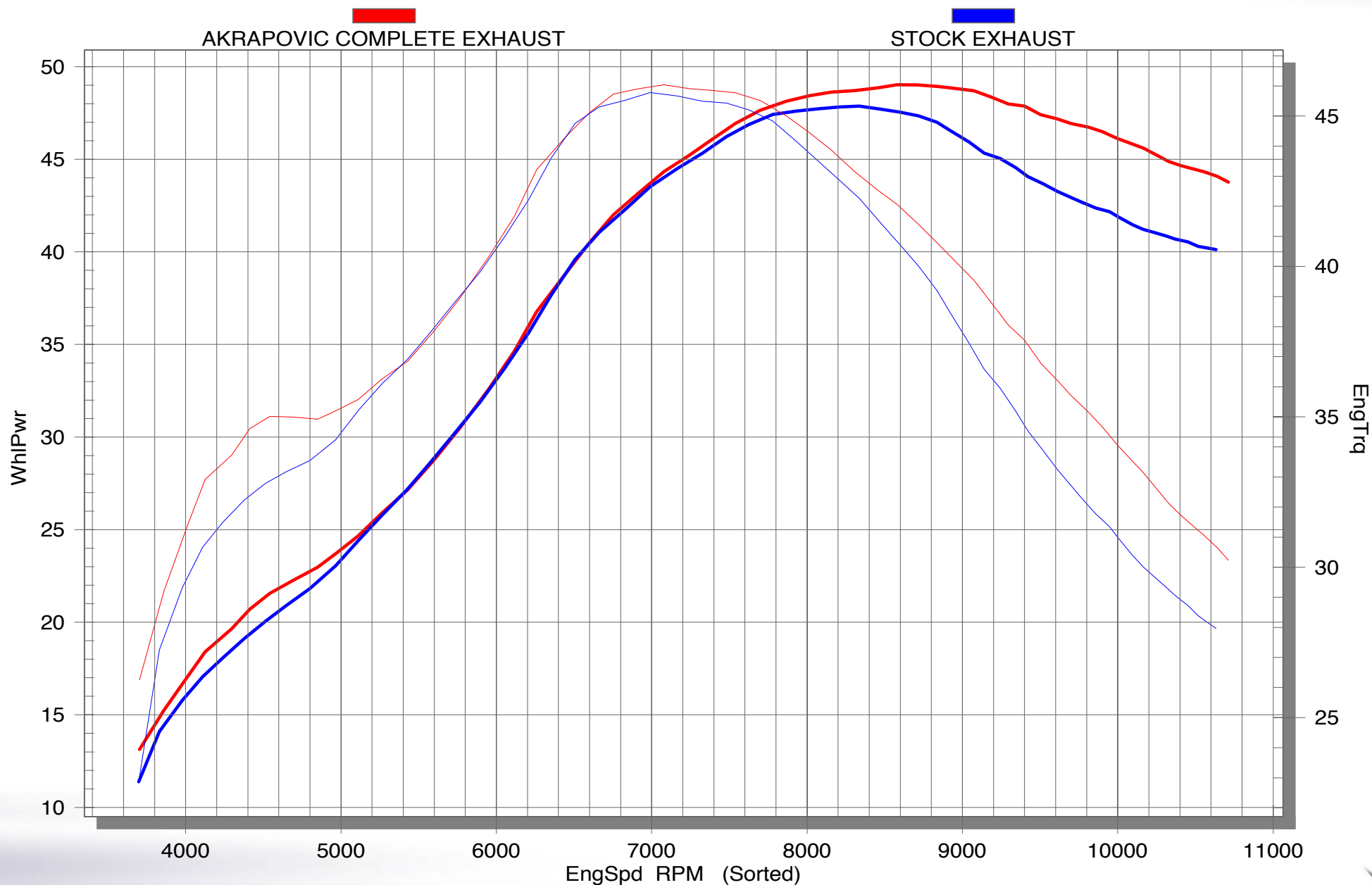

Off-Road Program

Product code: 107115 (S-S4MR5-QT), 107116 (S-S4MR5-QTA) US market  
107113 (S-S4MET5-QT), 107114 (S-S4MET5-QTA) US market

