



Yamaha YFM 350 R (2006)

Racing & Evolution Exhaust System

Akrapovic Racing / Evolution Exhaust System

for the Yamaha YZF 350 R (2006)

With the Akrapovic Racing and Evolution systems, we offer riders of the YFM 350 the possibility of a complete exhaust system replacement. Both systems are designed for riders who are looking for a top-quality system, in terms of both production quality and performance. The Akrapovic RACING and EVOLUTION systems are designed for two markets. For the European and other non-American markets they are available with a noise damper, and for the US market they come with an approved spark arrester.

PERFORMANCE

Measurements of the Akrapovic EVOLUTION system on the YAMAHA YFM 350 R (without muffler insert):

Power & Torque: the Akrapovic systems have a major effect on the power and torque curves. The increase can be seen at the low end, the middle and high revs, while at the top end they follow the stock figures. There is also increase in the overrev range.

CONFIGURATION

The Akrapovic Racing and Evolution systems are composed of a conical header tube, conical link pipe and a muffler. The only difference is in the tubing materials: the Racing uses stainless steel, while the Evolution uses titanium. The header tube and link pipe are connected using a sleeve joint secured with silicon-shielded springs. The link pipe is welded to the muffler in both systems. The material for the inlet cap and perforated inner sleeve depends on the material used for the link pipe (Evolution: titanium link pipe – titanium inlet cap and perforated inner sleeve; Racing: S.S. link pipe – S.S. inlet cap and perforated inner sleeve). The outlet cap for both systems is made of titanium. The muffler is attached to the ATV using an Akrapovic offroad carbon-fiber clamp. The system also includes an Akrapovic carbon-fiber heat shield. For the European and other non-American markets the systems come with a noise damper, and for the US market they come with an approved spark arrester, which is marked on the muffler with a laser engraving.

	PERFORMANCE		
	stock	AKRAPOVIC	max. increased power
max. rear wheel power HP / rpm (measured on Dynojet ATV)	23.3 / 7100	23.5 / 7800	1.8 / 4800

	CONFIGURATION		
	header tubes	collector	link pipe
material	STAINLESS STEEL (racing) TITANIUM (evolution)	-	STAINLESS STEEL (racing) TITANIUM (evolution)
tube shape	CONICAL	-	CONICAL

interference crossover tubes	-	lambda sensor	-	
header tube inner sleeves	S.S. CNC MACHINED	header tube flanges	S.S. LASER CUT	
header tubes - collector connection	-	collector / header tube - link pipe connection	SLEEVE JOINT + SILICON SHILDED SPRING	
link pipe - muffler connection	WELDED	muffler inlet cap / outlet cap	STAINLESS STEEL (racing) TITANIUM (evolution) / TITANIUM	
muffler metal interior	STAINLESS STEEL (racing) TITANIUM (evolution)	muffler outer sleeve	TITANIUM	
muffler clamp	CARBON-FIBER OFFROAD	muffler bracket	STAINLESS STEEL	
muffler insert	EU	NOISE DAMPER	heat shield	CARBON FIBER
	US	SPARK ARRESTER	catalytic converter	-

	ADDITIONAL DATA				
	stock	AKRAPOVIC		difference	
		RACING	EVOLUTION	stock - RACING	stock - EVOLUTION
weight comparison (kg)	5.05	3.01	2.48	2.04	2.57
noise measurements (dB / rpm)	stock		AKRAPOVIC		
	89 / 3500		94.6 / 3500		
possibility of periodic service without removing A.E.S.	oil		oil filter		
	YES		YES		
legal for street use	NO				

Technical specifications of Akrapovic exhaust systems and related products subject to change without notice.

Akrapovic Racing / Evolution Exhaust System for the Yamaha YZF 350 R (2006)



CARBON-FIBER
MUFFLER CLAMP

ATV
Series

Product code: Racing: 105461 (AS-Y3R1-DT) EU market , 105462 (AS-Y3R1-DTA) US market
Evolution: 105633 (AS-Y3ET1-DTT) EU market , 105634 (AS-Y3ET1-DTTA) US market

Akrapovic Racing / Evolution Exhaust System for the Yamaha YZF 350 R (2006)



Akrapovic Exhaust System Technology copyright 2005, all rights reserved

ATV
Series

Product code: Racing: 105461 (AS-Y3R1-DT) EU market , 105462 (AS-Y3R1-DTA) US market
Evolution: 105633 (AS-Y3ET1-DTT) EU market , 105634 (AS-Y3ET1-DTTA) US market



Akrapovic Racing / Evolution Exhaust System for the Yamaha YZF 350 R (2006)



Akrapovic Exhaust System Technology copyright 2005, all rights reserved

ATV Series

Product code: Racing: 105461 (AS-Y3R1-DT) EU market , 105462 (AS-Y3R1-DTA) US market
Evolution: 105633 (AS-Y3ET1-DTT) EU market , 105634 (AS-Y3ET1-DTTA) US market

Akrapovic Racing Exhaust System for the Yamaha YZF 350 R (2006)

Akrapovic Exhaust System Technology copyright 2005, all rights reserved

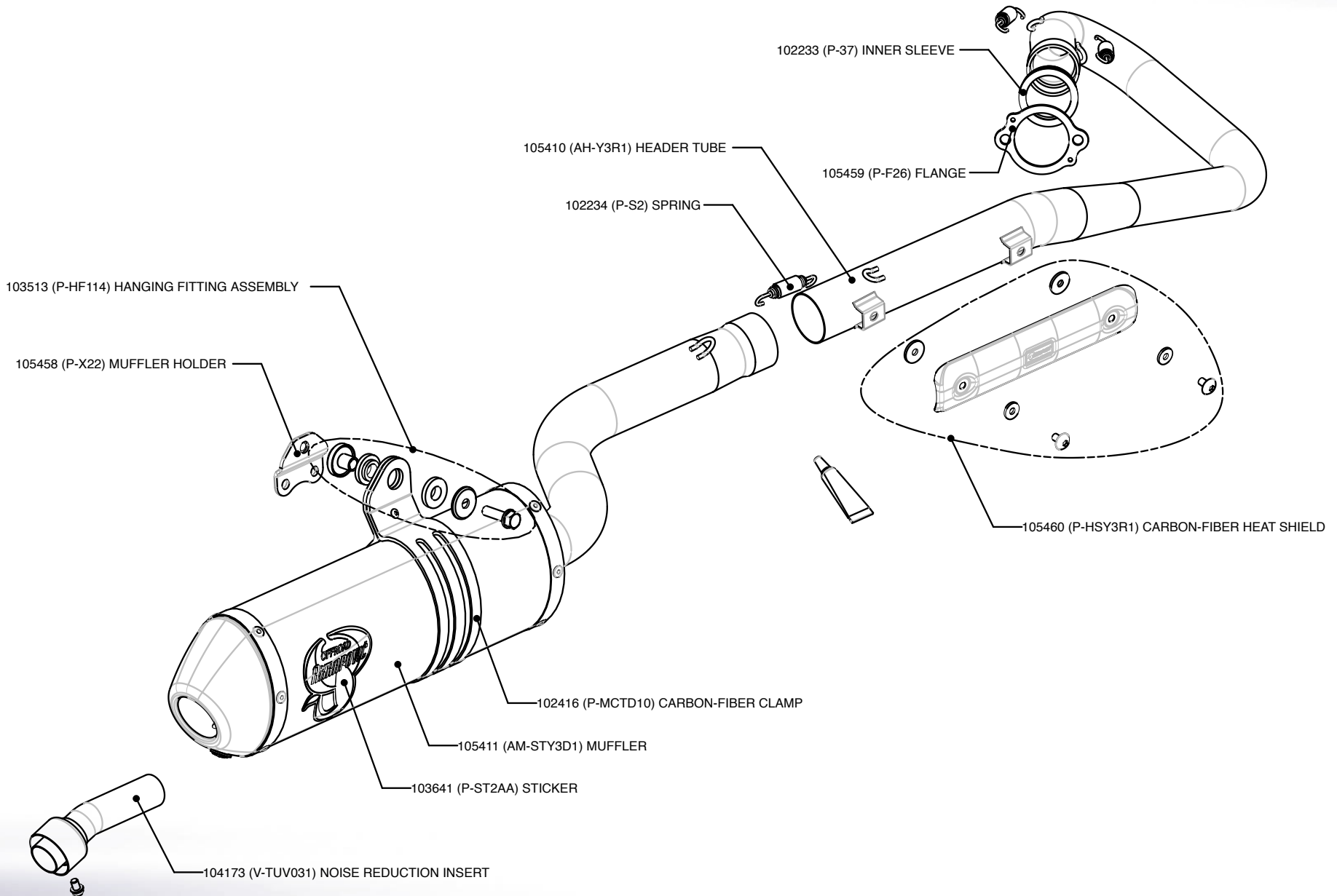

ATV
Series

Product code: 105461 (AS-Y3R1-DT) EU market



Akrapovic Racing Exhaust System for the Yamaha YZF 350 R (2006)

Akrapovic Exhaust System Technology copyright 2005, all rights reserved

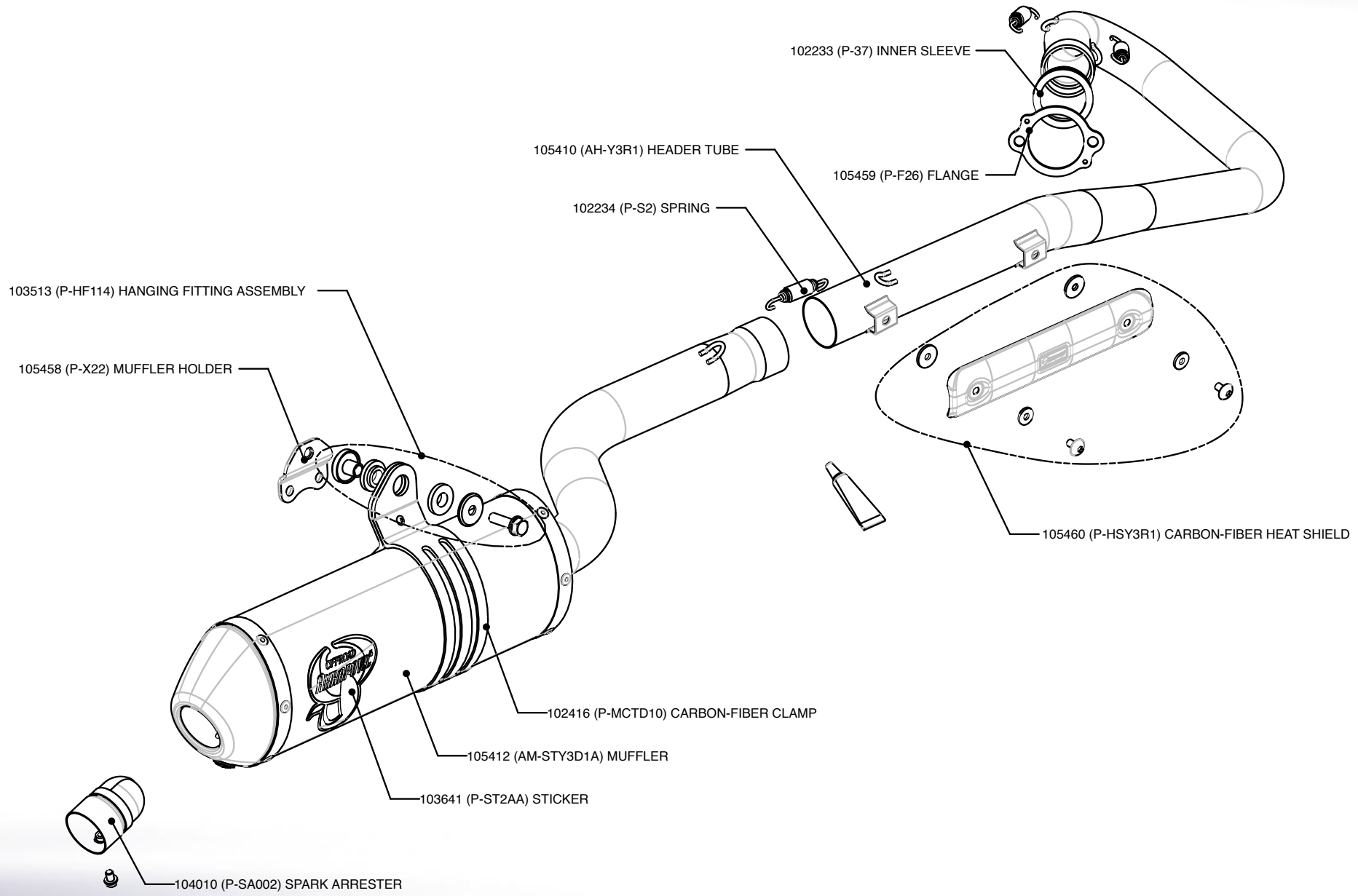

ATV
Series

Product code: 105462 (AS-Y3R1-DTA) US market



Akrapovic Evolution Exhaust System for the Yamaha YZF 350 R (2006)

Akrapovic Exhaust System Technology copyright 2005, all rights reserved

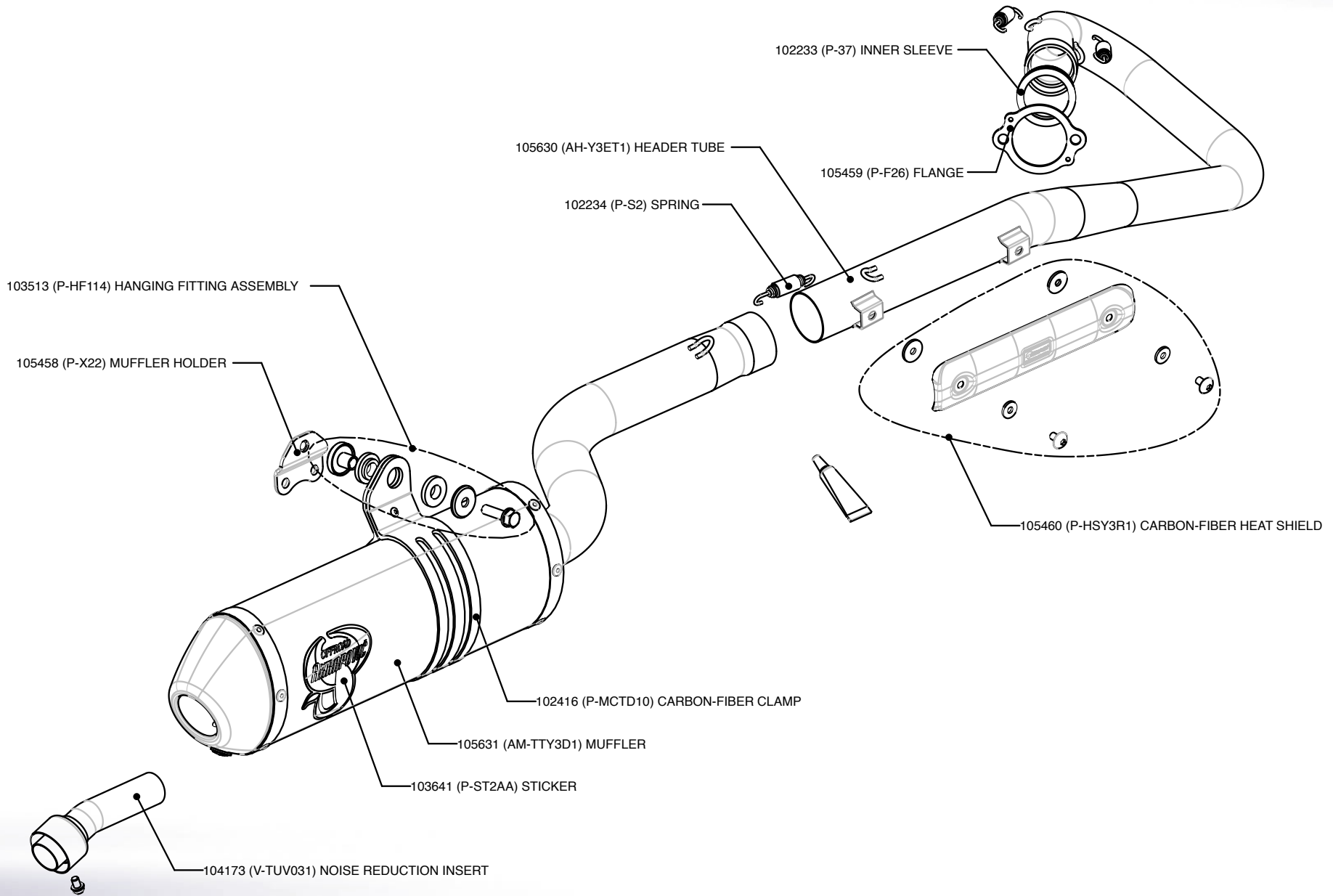

ATV
Series

Product code: 105633 (AS-Y3ET1-DTT) EU market



Akrapovic Evolution Exhaust System for the Yamaha YZF 350 R (2006)

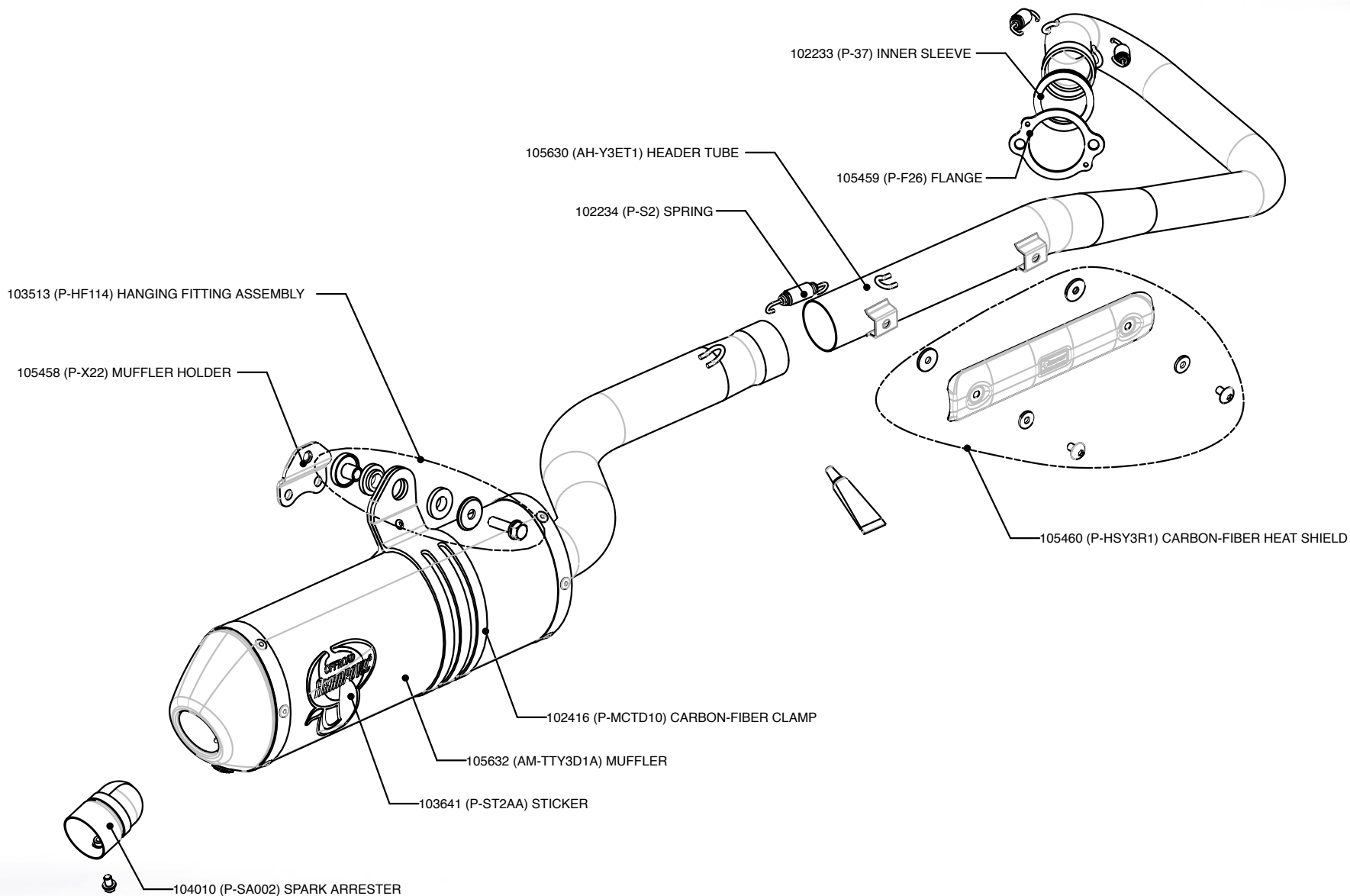

Akrapovic Exhaust System Technology copyright 2005, all rights reserved

ATV
Series

Product code: 105634 (AS-Y3ET1-DTTA) US market

Akrapovic Racing / Evolution Exhaust System for the Yamaha YZF 350 R (2006)

DYNOJET RESEARCH
AKRAPOVIC EXHAUST SYSTEM TECHNOLOGY

CF: SAE Smoothing: 5

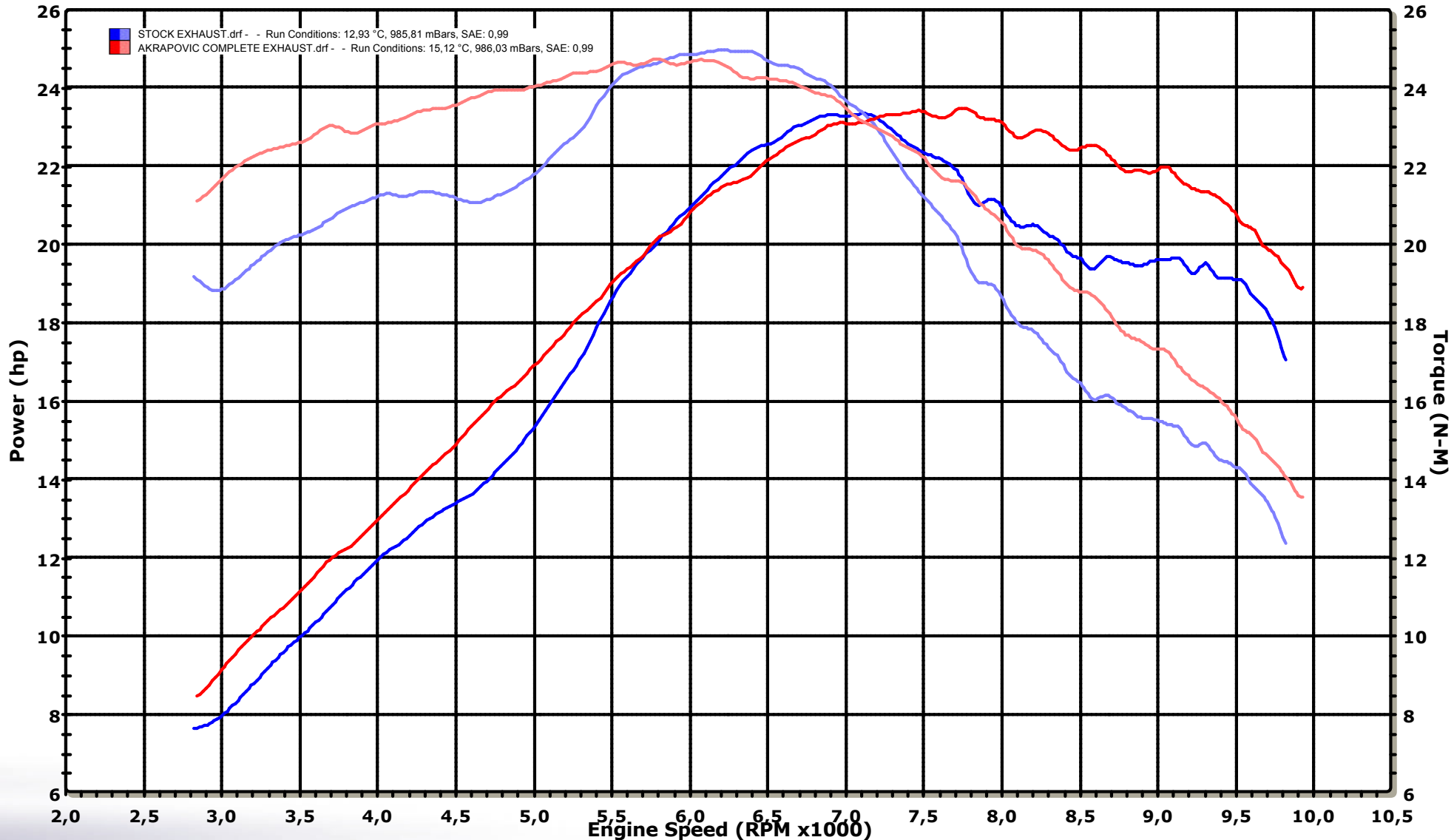

ATV Series

Product code: Racing: 105461 (AS-Y3R1-DT) EU market , 105462 (AS-Y3R1-DTA) US market
Evolution: 105633 (AS-Y3ET1-DTT) EU market , 105634 (AS-Y3ET1-DTTA) US market



Akrapovic Exhaust System Technology copyright 2005, all rights reserved