



Yamaha YZF R1 (2002 - 2003)

Slip-on Exhaust System

# Akrapovic Slip-On Exhaust System

## for the Yamaha YZF R1 (2002, 2003)

**A two-wheeled rocket made for everyone who loves the taste of outrageous top speeds, fantastic acceleration and superb braking. This year's model is no exception. The new R1 has improved mechanical features as well as a revamped appearance. Recognizable from a distance, its sharp lines set the standards for design, and its performance sets a tough challenge for the competition.**

### GOAL

It is hard to resist such a resounding name as the R1, the bike against which all other Supersport motorcycles are measured. This was definitely a special challenge for our company: Were we capable of improving this already fantastic machine? The results are clear. The Akrapović development department have once again shown their prowess and developed an Akrapovic SLIP-ON system for the Yamaha R1. This system will flaunt how much you value high technology design and materials and top-level production quality.

### ABOUT AKRAPOVIC SLIP-ON SYSTEMS

You are probably already satisfied with the look of your bike, but you're looking for that final touch to make it a true sports machine. The Akrapovic SLIP-ON system is the answer!

The idea of the Akrapovic SLIP-ON system is to change the look and sound of your bike with minimum modification. The Akrapovic SLIP-ON system completely fulfils this demand. The sound of the R1 will allow the bike to express its character, as will outer sleeve of the muffler, with the familiar checkerboard pattern of carbon-fiber or the bright sheen of titanium..

The system includes a muffler, available as stated in either titanium or carbon-fiber versions, a carbon-fiber muffler clamp and a link pipe. The latter is also available in two

versions – titanium or high-quality stainless steel. Performance is identical for all combinations. The choice depends entirely on the taste of the rider. Installation of the Akrapovic SLIP-ON system is simple and can be performed by the customer.

The system is secured to the stock header assembly using a metal clamp aided by high-quality silicon-shielded springs, while the muffler is attached with the renowned Akrapovic carbon-fiber clamp. No modification is necessary to any of the stock parts, and the stock mounting positions are used.

### Measured performance of the Akrapovic SLIP-ON system on the Yamaha R1:

#### • power:

with a minimal and simple alteration to the back end of the bike, we have achieved an exceptional amount of increased power. The Akrapovic SLIP-ON system builds on the stock power curve throughout the entire rpm range. But the greatest advantage is the complete elimination of the fluctuations in the power curve in the ranges from 3200 – 4400 rpm and 5600 – 8200 rpm. This indicates exceptionally stable and linear transfer of engine power with the use of the Akrapovic SLIP-ON system.

#### • torque:

the Akrapovic SLIP-ON system shows its colors in the torque curve of the Yamaha R1. Once again we have managed almost completely to eliminate the engine fluctuations which appeared in the range from 3000 rpm to the top of the power band. With the use of our system these drop-outs are well filled, making the motor much more rider-friendly.

If you do not wish to make any substantial modification to your bike, then the Akrapovic SLIP-ON system is an excellent compromise, offering aesthetic enhancement of the lines of the bike, exceptional product quality, a renowned brand name, substantial weight savings, an instantly recognizable sound and a significant increase in overall performance, all at an exceptionally affordable price.

For those who desire even higher performance, we also offer a range of complete exhaust systems for this year's Yamaha R1.

|                       | stock            | AKRAPOVIC            |          | difference       |                  |
|-----------------------|------------------|----------------------|----------|------------------|------------------|
|                       |                  | S.S.                 | titanium | stock - S.S.     | stock - titanium |
| weight comparison     | 4.60 kg          | 2.20 kg              | 1.95 kg  | 2.40 kg          | 2.65 kg          |
| max. rear wheel power | 135 / 10600 RPM  | 138.1 HP / 11000 RPM |          | 5 HP / 7500 RPM* |                  |
| noise measurement     | 92 db / 5250 RPM | 98.5 db / 5250 RPM   |          | 6.5 db / 6500RPM |                  |
| legal for street use  |                  | NO                   |          |                  |                  |

\*MAXIMUM MEASURED POWER DIFFERENCE

Technical specifications of Akrapovic exhaust systems and related products subject to change without notice.

# Akrapovic Slip-On Exhaust System for the Yamaha YZF R1 (2002, 2003)

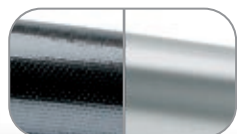

The outer sleeve is available in carbon-fiber or titanium

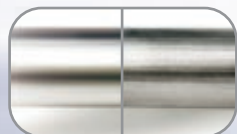

Link pipe is made of stainless steel or sandblasted titanium (optional)



CARBON-FIBER  
MUFFLER CLAMP

Product code: S-Y10SO5-T, S-Y10SO5-C, S-Y10SO5T-T, S-Y10SO5T-C



# Akrapovic Slip-On Exhaust System for the Yamaha YZF R1 (2002, 2003)



Akrapovic Exhaust System Technology copyright 2003, all rights reserved

Road Program

# Akrapovic Slip-On Exhaust System for the Yamaha YZF R1 (2002, 2003)



Akrapovic Exhaust System Technology copyright 2003, all rights reserved

Road Program

# Akrapovic Slip-On Exhaust System for the Yamaha YZF R1 (2002, 2003)

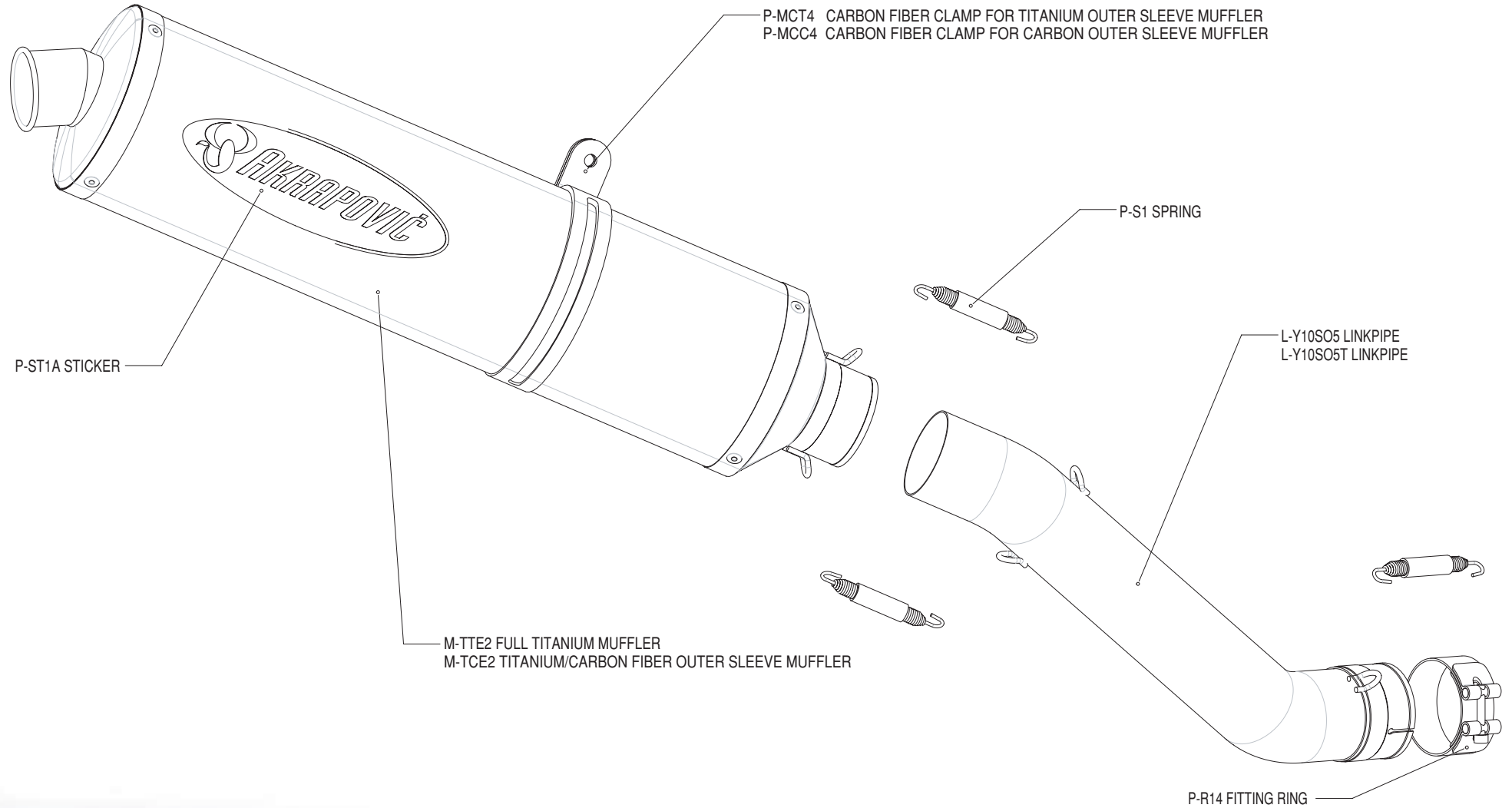

Akrapovic Exhaust System Technology copyright 2003, all rights reserved

Road Program





# Akrapovic Slip-On Exhaust System for the Yamaha YZF R1 (2002, 2003)

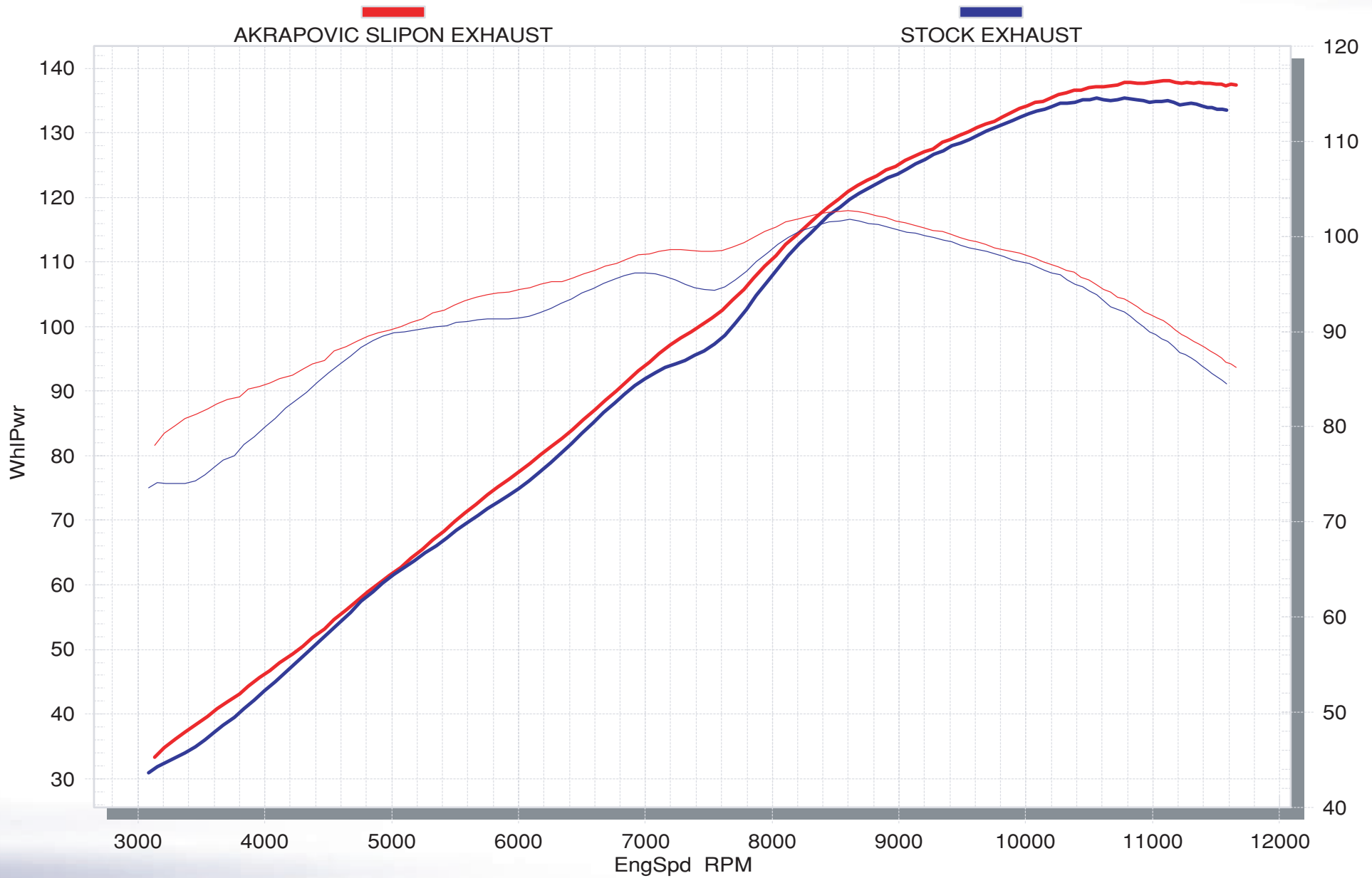

Akrapovic Exhaust System Technology copyright 2003, all rights reserved

Road Program

